

Infra-red Thermometer

Instruction Manual

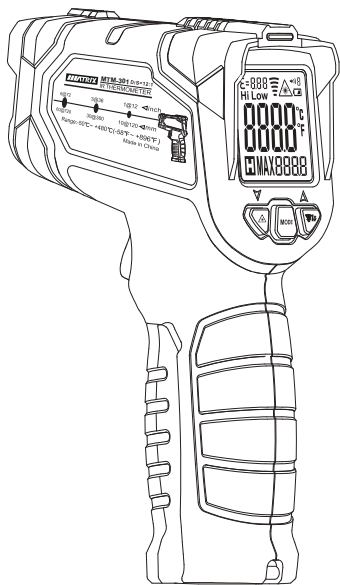

Thank you for choosing MATRIX .

Before you use this product please read this manual carefully as it will familiarize you with the correct operating procedure for your MATRIX Infra-red thermometer.

MATRIX strictly abide by the internal standards of enterprises and the national metrological verification regulations of the People's Republic of China.

Infra-Red Radiation Thermometer for Work (JJG415-2001) production and inspection.

⚠ Warning: Laser radiation is harmful to human eyes. Do not directly shine the laser beam directly into the eyes. Be careful not to indirectly shine beam into eyes via reflective surfaces.

⚠ Note: Before using this instrument, please read the instructions in detail.

I. Product introduction

This series of hand-held infra-red thermometer is a high-performance and high-quality instrument which is designed for professional and scientific use.

Features include adjustable emissivity measurement, maximum value hold and a customisable alarm for high or low values. The key benefits of your new MATRIX Infra-red thermometer include high measurement accuracy, fast measurement response, simple operation and professional reliability in a small, portable form factor. This product has been designed for use in the petrochemical industry, railway industry and electric power industry as well as textile, plastics and metal processing facilities, among many others.

All objects above absolute zero radiate heat energy continuously. The MATRIX Infra-red thermometer uses invisible Infra-red light to measure this heat energy- this is infra-red thermometry.

The thermometer features an infra-red optical system which gathers radiated energy in the field of view- this is imaged on the infra-red detector which converts this energy into an electrical signal which is processed by the computer and displayed on screen as the temperature of the object.

II. Panel introduction

1. Symbol of temperature measurement state
2. Laser lamp indicators
3. Low voltage prompt symbol
4. Celsius unit symbol
5. Fahrenheit unit symbol
6. Temperature display area
7. Maximum value display area
8. Emissivity symbol
9. High temperature alarm symbol
10. Low temperature alarm symbol
11. Data hold symbols
12. Maximum value symbol
13. Laser turn-on and turn-off button
14. Function switching button
15. Turn on and off the prompt tone button

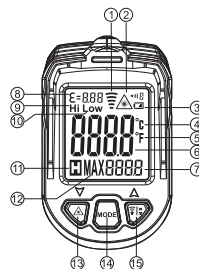

III. Instructions for use

1. Basic operations

Hold down the temperature measuring trigger and turn the instrument on. Aim the thermometer at the target using the red laser circle projected by the thermometer. The laser point should be aimed at the center of the target under test. The LCD screen will then display the real-time temperature of the target object. At the same time, it also shows the following symbol: ☼. When you release the temperature measurement trigger, the measurement stops, and the screen will display 'H'. The displayed temperature value and 'H' symbol will be held for 15 seconds. The thermometer will go to sleep after 1 minute of inactivity to preserve battery life. The instrument can be woken up by pressing the temperature measuring trigger or MODE key.

2. Setting alarm value for high and low temperature

Press and hold the MODE button for 2 seconds- the thermometer will enter the settings interface. The screen displays Hi: high temperature alarm value setting (default value = 360°C). By then pressing the UP (▲) or DOWN (▼) button this high alarm value can then be set. Once you have set your alarm value, press the MODE button once again and the screen will display Low: low temperature alarm value setting (default value = - 20°C). Once again, pressing the UP (▲) or DOWN (▼) button sets the low alarm value. Press and hold the MODE button for 2 seconds to save your settings- measurement can now be resumed as normal. Pressing the temperature measuring trigger will also exit the setting interface. The setting data will be stored in the device RAM. After replacing the battery these settings will be reset to the initial value of high temperature alarm value 360°C and low temperature alarm value -20°C.

3. Emissivity setting

Turn the instrument on by pressing the temperature measuring trigger. The LCD screen will display the emissivity symbol 'ε=' and the emissivity value (the starting preset is 0.95 and is adjustable between 0.1 and 1.00). Press and hold the MODE button for 2 seconds- the thermometer will enter the settings interface. Pressing the MODE key twice while in settings mode will cause the emissivity symbol 'ε=0.95' to blink. At this time, the emissivity can be adjusted by pressing the UP (▲) or DOWN (▼) button. Holding the up or down button for more than 2 seconds will cycle through emissivity settings rapidly. Press and hold the MODE key again for 2 seconds to exit the setting interface and save your emissivity setting. Pressing the temperature measuring trigger will also exit the settings interface.

4. Celsius/Fahrenheit switching °C/°F conversion, laser turn on and off, prompt tone turn off

Press the temperature measuring trigger to turn the thermometer on and press the MODE key to cycle between °C/°F conversion. Press the temperature measuring trigger to turn the instrument on. Press ▲ key to turn on or turn off the laser lamp. ☼ symbol indicates that the laser lamp is turned on. Press the temperature measuring trigger to turn the instrument on, press ☼ key to turn off and turn on prompt tone.

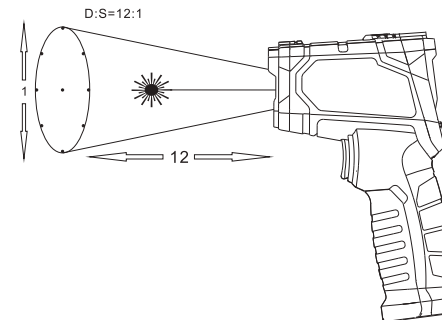

IV. Technical specifications

1. MTM-301/302

Item	MTM-301	MTM-302
Temperature measuring range	-50°C~480°C -58°F~896°F	-50°C~680°C -58°F~1256°F
Measurement accuracy	0°C~480°C ± (1.5%+1°C) 32°F~896°F ± (1.5%+5°F) -50°C~0°C (±3°C) -58°F~32°F (±5°F)	0°C~680°C ± (1.5%+1°C) 32°F~1256°F ± (1.5%+5°F) -50°C~0°C (±3°C) -58°F~32°F (±5°F)
Repeatability accuracy	±0.5% or ±1°C (2°F)	
Display resolution	0.1°C (0.1°F)	
Response time and wavelength	Less than 500ms 8~14um	
Emissivity	0.1~1.00 adjustable(step size 0.01)	
Measuring object distance ratio	12:1	
Laser aiming	Less than 1mW 650nm Laser grade II grade	
°C/°F conversion	✓	
Screen display mode	VA color screen	
Backlight display	✓	
Overrange prompt	"HI" or "LO"	
Power supply	1.5V x2 AAA	
Working environment temperature	0°C~50°C	
Working environment humidity	10~95%RH Non condensing	
Storage temperature	-20°C~60°C Not including batteries	
Product size	155x92x42mm	
Product net weight	About 180g	

2. MTM-304/305

Item	MTM-304	MTM-305
Temperature measuring range	-50°C~880°C -58°F~1616°F	-50°C~880°C -58°F~1616°F
Measurement accuracy	0°C~880°C ± (1.5%+1°C) 32°F~1616°F ± (1.5%+5°F) -50°C~0°C (±3°C) -58°F~32°F (±5°F)	
Repeatability accuracy	±0.5% or ±1°C (2°F)	
Display resolution	0.1°C (0.1°F)	
Response time and wavelength	Less than 500ms 8~14um	
Emissivity	0.1~1.00 adjustable(step size 0.01)	
Measuring object distance ratio	12 : 1	
Laser aiming	Less than 1mW 650nm Laser grade II grade	
K type probe temperature measurement	×	√
Environmental temperature and humidity display	×	√
°C/°F conversion	√	√
Screen display mode	VA color screen	
Backlight display	√	√
Overrange prompt	“HI” or “LO”	
Power supply	1.5V x2 AAA	
Working environment temperature	0°C~50°C	
Working environment humidity	10~95%RH Non condensing	
Storage temperature	-20°C~60°C Not including batteries	
Product size	155x92x42mm	
Product net weight	About 180g	

V. Emissivity chart

Method for determining emissivity

Method for determining emissivity:

1.Measuring the emissivity of materials by direct measurement Measure actual temperature using a contact thermometer. Then use the infra-red thermometer to measure it and adjust the emissivity value until the displayed temperature is equal to the actual temperature.

2.Materials with lower emissivity can not be measured by direct measurementStick black tape or spray aerosol black paint onto the surface of the material object to be measure (black tape and black paint have an emissivity of ε ≈ 0.95). When the temperature of the material reaches equilibrium, use the infra-red thermometer to measure the temperature of the covering material. Now adjust the emissivity of the thermometer so that the temperature displayed when measuring an area not covered by tape/paint is the same as the covered area.

To determine the emissivity value of an object please refer to Appendix 1 and 2 in this manual (for reference only)

Appendix 1:

Emissivity of common metal surfaces		
Material	Emissivity value	
Aluminum	Non oxidation	0.02—0.10
	Oxidation	0.02—0.40
Alumina	Oxidation	0.30
	Alumina	0.10—0.30
	Rough	0.02—0.10
Brass	Polished	0.01—0.05
	Polished	0.30
	Oxidizing	0.50
Chromium		0.02
Copper	Polished	0.03
	Polished	0.05—0.10
	Oxidizing	0.40—0.80
Gold		0.01—0.10
Nickel-chromium-iron alloy	Oxidizing	0.70—0.95
	Frosted	0.30—0.60
	Electrolytic polishing	0.15
Iron	Oxidizing	0.50—0.90
	Non-oxidizing	0.05—0.20
	Rusty	0.50—0.70
Cast iron	Oxidizing	0.60—0.95
	Non-oxidizing	0.20
	Melting	0.20—0.30

Wrought iron	Dull	0.90
	Polished	0.05—0.10
Lead	Rough	0.40
	Oxidizing	0.20—0.60
Magnesium		0.02—0.10
Mercury		0.05—0.15
Molybdenum	Oxidizing	0.20—0.60
	Non-oxidizing	0.10
Nickel copper gold		0.10—0.14
Nickel	Oxidizing	0.20—0.50
	Electrolytic	0.05—0.15
Platinum black		0.90
Silver		0.02
Tin	Non-oxidizing	0.05
Tungsten	Polished	0.03—0.10
	Cold rolling steel	0.70—0.90
	Raw board	0.40—0.60
Steel	Cast steel plate	0.10
	Oxidizing	0.70—0.90
	Stainless steel	0.10—0.80
Titanium	Polished	0.05—0.20
	Oxidizing	0.05—0.20
Zinc	Oxidizing	0.10
	Polished	0.02

Appendix 2:

Emissivity of common non-metal surfaces		
Material	Emissivity value	
Asbestos		0.95
Asphalt		0.95
Basalt		0.70
Brick	Red	0.93
Emery		0.90
Ceramics		0.95
Clay		0.95
Concrete		0.95
Cloth		0.95
Glass		0.85
Gravel		0.95
Gypsum		0.85—0.95
Ice		0.95
Paint	Colorless transparent	0.92
	Dark black	0.97
Rubber		0.95
Lime		0.98
Coatings are alkaline-free		0.90—0.95
Paper of any color		0.95
Plastic opacity		0.95
Snow		0.90

Soil	Dry	0.92
Mud		0.95
Water		0.93
Sand (crude ore)		0.90
Natural wood		0.90—0.95

VI. Notes

1. The relationship between temperature measurement and target size and distance

The relationship between the distance from the target and the size of said target is expressed by the object distance ratio. This is displayed as (D:S). D:S is the optical index of the infra-red thermometer. By determining the object distance ratio, the correct measuring distance can be determined according to the size of the target. The ideal object distance ratio is 2:1. In order to reduce the error in actual measurement, the size of the target should fill the field of view measured by the instrument. Therefore, it is ideal to stand close enough to the object that it is twice the size of the field of view of the thermometer.

2. Effect of emissivity on temperature measurement

Because the material and surface conditions of objects are often different, the emissivity of objects is different. In order to compensate for the measurement errors caused by different emissivity, the emissivity value of the instrument should be adjusted according to the material of the object. (Appendix includes the determination methods of emissivity and emissivity of some materials for reference).

3. ☠ Laser radiation is harmful to human eyes

Don't point the laser beam into people's eyes when using the thermometer.

The technical specifications of the laser used in the infrared thermometer are as follows:

Outlet power: <1mW

Wavelength: 650 nm

Laser grade: Grade II

Operating distance: about 30m

4.Preserving the thermometer

Your infra-red thermometer should avoid contact with overheated objects, objects with strong magnetism, high voltage or corrosive substances such as lipids, ketones, ethylene and dichlorides.

VII. Instrument maintenance

1.Lens cleaning

After using the infrared thermometer for an extended period of time the lens will accumulate dust. This can be blown away using a cleaning ball or cleaned with a small amount of clean water on a clean cotton swab.

2. Shell cleaning

A soft cloth with a neutral cleaning solution can be used to wipe the thermometer shell.

3. Replacement of batteries

When '☐' appears on the LCD screen please replace the battery. In order to protect the environment, please properly dispose of waste batteries.

Remember: once the battery has been replaced stored settings on the device will need to be re-input.

4. Storage

When the instrument will not be used for an extended period please take out the battery and store both it and the thermometer safely.

5.Faults and Warranty

If the thermometer fails please contact the manufacturer,MATRIX , or your distributor who will be able to confirm a fault and repair the item. When sending instruments for warranty claims and repairs you should provide a detailed written description of the device failure and a packing list within the parcel. The product must be well packaged for returns to avoid further damage which will not be covered by the manufacturer.

☐ Special Statement

➤ Used batteries must be in accordance with local laws and regulations to deal with!

➤ The Company reserves the right to update and modify the design of the product specifications and manual contents are subject to change without prior notice!



MATRIX TECHNOLOGY INC.

Address: No. 206, Building D, Huachuangda Culture and Technology Industrial Park, Haihui Road, 49 th Area, Bao'an District, Shenzhen, Guangdong, China

TEL : 86-755-2836 4276

P C : 518102

E-mail : sales@szmatrix.com

Http : /www.szmatrix.com