

F-NIRSI 菲尼瑞斯

TSG3020/TSG6020

函数信号发生器用户手册 V1.1

FUNCTION SIGNAL GENERATOR USER MANUAL

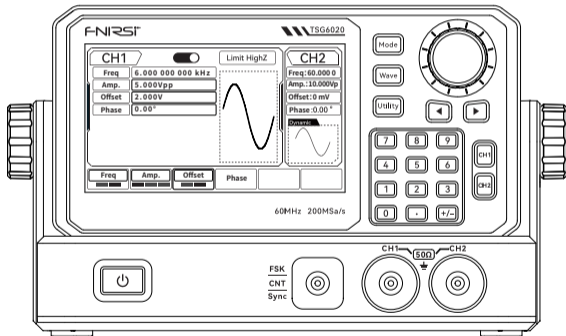

※使用产品前请仔细阅读本说明书, 并妥善保管。

※Please read this instruction manual carefully before using the product and keep it properly.

目录

一、安全信息 >>>	01	二、产品概览 >>>	02
三、快速入门 >>>	08	四、高级运用 >>>	14
五、故障处理 >>>	41	六、维护保养 >>>	41
七、生产信息 >>>	42	八、保修说明 >>>	43
附录A、出厂重置状态 >>>	44	附录B、性能指标 >>>	48
附录C、配件清单 >>>	59	保修卡 >>>	页末



CONTENTS

1.SAFETY INFORMATION >>>	60	2.PRODUCT OVERVIEW >>>	62
3.QUICK START >>>	68	4.ADVANCED USAGE >>>	75
5.TROUBLESHOOTING >>>	104	6.MAINTENANCE >>>	105
7.CONTACT US >>>	107	8.WARRANTY INFORMATION >>>	108
APPENDIX A: FACTORY RESET STATUS >>>	109	APPENDIX B: PERFORMANCE SPECIFICATIONS >>>	113
APPENDIX C: ACCESSORIES LIST >>>	124	WARRANTY CARD >>>	Last Page



一、安全信息

1.1 安全术语和符号

以下术语可能出现在本手册中:

-  **警告:**警告性声明,指出可能会危害生命安全的条件和行为
-  **注意:**注意性声明,可能导致此产品或其它财产损坏的条件和行为

以下术语可能出现在产品上:

-  **危险:**表示如果进行此操作可能会造成伤害
-  **警告:**表示如果进行此操作可能会有危险
-  **注意:**表示如果进行此操作可能会对本产品或连接到本产品的其他设备造成损坏

1.2 一般安全概要

本产品严格遵循GB4793电子测量仪器安全要求以及IEC61010-1安全标准进行设计和生产。符合绝缘过电压标准CATI300V和污染等级1的安全标准。请阅读下列安全性预防措施:

- 为防止触电或失火,请使用本产品专用并在使用国家(地区)核准的电源线及电源适配器。
- 本产品通过电源线内的保护接地线接地。

- 为防止电击,使用前请检查电源插座是否与大地相连接。
- 在连接除电源线外的输入或输出端之前,确认保护接地端与电源接地端有可靠的连接为避免人身伤害、防止设备损坏,只有受过专业培训的人员才能对设备进行维修。
- 为了防止火灾或电击危险,请注意产品额定工作范围及产品标记。
- 禁止在额定值范围外工作。
- 使用前,请检查附件是否有机械损伤,如发现损伤,请勿使用并及时更换。
- 仅使用本产品配置的附件。
- 禁止将金属物体插入本产品的输入、输出端。
- 如怀疑本产品有损坏,需专业维修人员进行检查。
- 禁止在仪器机箱开启状态下运行本产品。
- 请勿在潮湿的环境下操作。
- 保持产品表面清洁和干燥。

二、产品概览

2.1 主要特点

- 双通道,最大输出频率 60MHz/30MHz,最大输出幅度20Vpp;
- 高精度DDS频率合成技术,具有200MSa/s采样率和14bits垂直分辨率;

- 采用创新的 **ZeroSurge** 技术,输出方波 / 脉冲波 / 斜波的过冲更低、边沿更快、精度更高。占空比、脉宽、边沿、对称度精细可调;
- 采用创新的 **VeriPoint** 技术,逐点输出任意波,以1uSa/s~200MSa/s无极变速采样率输出4Kpts长度内的低抖动波形,并且保留波形所有细节;
- 兼容TTL电平信号的7位高精度频率计;
- 24组非易失数字任意波形存储;
- 丰富的模拟和数字调制功能:AM、FM、PM、ASK、PSK、FSK;
- 支持频率扫描输出;
- 4.3”TFT-LCD 触摸显示屏与键盘双操作方式;
- 标准配置接口:USB Device, Type-C 电源接口,支持移动电源供电,可应对现场测试需求。

2.2 输出特性

通道	CH1, CH2
幅度范围	2mVpp~20Vpp(高阻、<10MHz) / 2mVpp~10Vpp(高阻、>10MHz) / 1mVpp~10Vpp(50Ω、<10MHz) / 1mVpp~5Vpp(50Ω、>10MHz)
波形	正弦波,方波,脉冲波,斜波,任意波,噪声,直流
调制	AM, FM, PM, ASK, PSK, FSK
扫频	线性扫频、对数扫频

2.3 面板和按键介绍

▶2.3.1 前面板

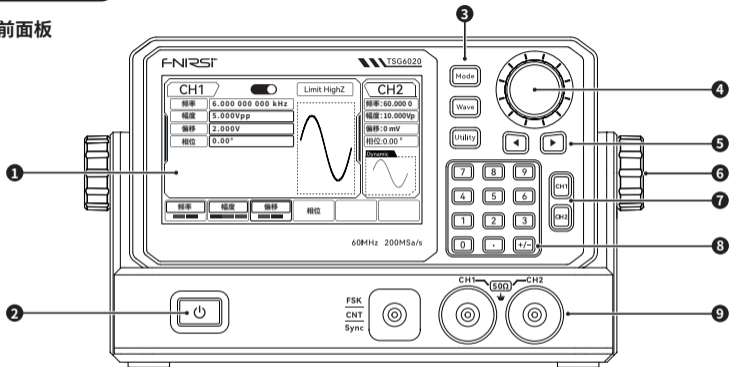

①**显示屏**:4.3寸高分辨率TFT彩色液晶显示屏通过色调的不同明显得区分通道一和通道二的输出状态、功能菜单和其它重要信息。

②**电源开关**:设备开机时按键指示灯高亮,长按关机。

- ③**功能按键**:功能按键有Mode, Wave, Utility, 通过这些按键进行调制设置, 基波选择和辅助功能设置等。
- ④**多功能旋钮/按键**:旋转多功能旋钮改变数字(顺时针旋转数字增大)或作为方向键使用, 按多功能旋钮可选择功能或确定设置的参数。
- ⑤**方向键**:在使用多功能旋钮和方向键设置参数时, 用于切换数字的位置。
- ⑥**调整旋钮**:通过旋钮可调整屏幕方向使获得更舒适的观看角度, 最大可旋转90°。
- ⑦**CH1/CH2控制输出键**:快速切换在屏幕上显示的当前通道, 快速开启/关闭通道输出。打开通道输出时, 背光灯亮, 同时在信息标签会显示输出的功能模式(若开启高级功能)。关闭时CH1键或CH2键背光灯灭, 同时关闭输出端。
- ⑧**数字键盘**:用于输入所需参数的数字键0至9、小数点"."、符号键"+/-"。
- ⑨**输出端口**:从左到右依次为同步输出端/频率计输入端、CH1输出接口、CH2输出接口。频移键控、同步信号和频率计共用一个端口。

⚠ 注意:

- 通道输出端设有过压保护功能, 满足下列条件之一则产生过压保护。
- 仪器幅度设置大于250mVpp, 输入电压大于 $|\pm 12.5V|$, 频率小于10kHz。
- 仪器幅度设置小于等于250mVpp, 输入电压大于 $|\pm 2.5V|$, 频率小于10kHz。
- 产生过压保护时, 通道自动断开输出。

► 2.3.2 后面板

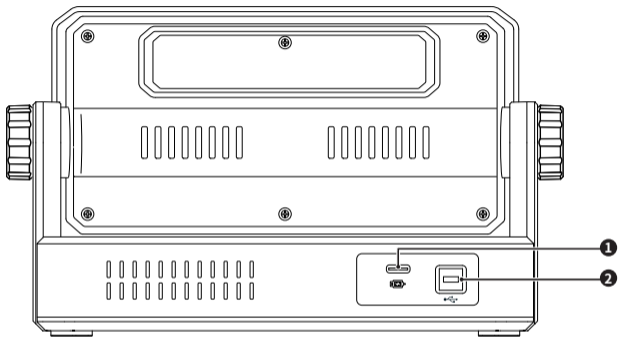

- ①**电源接口**:额定输出值为5V,2A。需要信号发生器输出高信噪比的信号,建议使用官方标配电源适配器。
- ②**USB接口**:通过此USB接口与上位机连接,实现远程通信。

▶ 2.3.3 用户界面

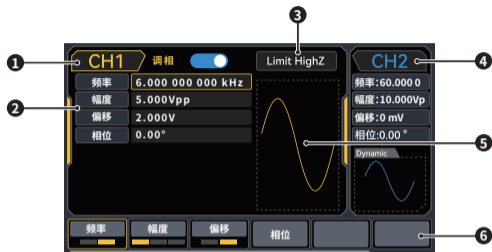

① **CH1输出开关**: 点击可开启通道1输出, 按键切换蓝色表示输出打开。

② **波形参数列表**: 以列表的方式显示当前波形的各种参数, 如果列表中某一项显示黄色框选中, 则可以通过菜单操作软键、数字键盘、方向键、多功能旋钮的配合进行参数设置。如果当前字符底色为当前通道的颜色, 说明此字符进入编辑状态, 可用方向键或数字键盘或多功能旋钮来设置参数。

③ **负载信息**: “Limit HighZ”表示输出端匹配的阻抗为高阻(1 Ω 到9999 Ω 可调, 出厂默认为高阻), 点击可快捷到负载设置界面。

④**CH2压缩界面**:当某一通道信息被压缩时,可在该区域滚动显示输出波形信息。点击该区域“CH2”处和波形显示区可以展开当前通道设置界面。展开内部的信息设置同上。

⑤**波形显示区**:显示该通道当前设置的波形形状(可通过颜色来区分是哪一个通道的当前波形,左边的参数列表显示该波形的参数)。点击该区域可进行波形快捷选择切换。注:系统设置时没有波形显示区,此区域被扩展成参数列表。

⑥**软键标签**:波形选择和菜单操作软件菜单。当显示黄色选择框时表明选中状态。

三、快速入门

3.1 一般性检查

当您得到一台全新的产品时,建议按以下步骤对仪器进行检查。

▶ 3.1.1 运输外观检查

- 如果发现包装纸箱或泡沫塑料保护垫破损严重,请与经销商或本公司当地办事处联系。
- 如果因运输造成仪器的损坏,请注意保留包装,通知运输部门和经销商,经销商会安排维修或更换。

▶ 3.1.2 检查附件

- 附件包括:电源适配器、一根BNC电缆(1米)、一根BNC转鳄鱼夹传输线、一份产品保修卡。
- 如果发现附件缺少或损坏,请和经销商或本公司当地办事处联系。

▶ 3.1.3 检查整机

- 如果发现仪器外观破损, 仪器工作不正常, 或未能通过性能测试, 请和经销商或本公司当地办事处联系。

3.2 输出基本波形

▶ 3.2.1 设置正弦波输出频率

波形默认配置: 频率为1kHz, 幅度为100mV峰峰值的正弦波。

将频率改为1MHz的具体步骤如下:

依次点击屏幕波形区域或按【Wave】→【正弦波】→【频率】, 使用数字键盘输入1, 然后选择参数单位MHz。

▶ 3.2.2 设置正弦波输出幅度

波形默认配置为: 幅度为100mV峰峰值的正弦波。

将幅度改为1Vpp的具体步骤如下:

依次点击屏幕波形区域按【Wave】→【正弦波】→【幅度】, 使用数字键盘输入1, 然后选择参数单位Vpp。

▶ 3.2.3 设置正弦波偏移电压

正弦波默认偏移电压为0V, 将偏移电压改为-150mv的具体步骤如下:

依次点击屏幕波形区或按【Wave】→【正弦波】→【偏移】, 使用数字键盘输入-150, 然后选择参数单位mVpp。

※注: 多功能旋钮和方向键的配合也可进行此参数设置。

►3.2.4 设置相位

波形默认相位为 0° ，将相位设置为 90° ，按相位键，使用数字键盘输入90，然后选择参数单位。

►3.2.5 设置脉冲波占空比

脉冲波默认频率为1MHz，占空比为50%，以占空比为25%，具体步骤如下：

依次点击屏幕波形区或按【Wave】→【脉冲波】→【占空比】，使用数字键盘输入25，然后选择参数单位%。

►3.2.6 设置斜波对称度

斜波默认频率为1kHz，以对称度为75%的三角波为例，具体步骤如下：

依次点击屏幕波形区或按【Wave】→【斜波】→【对称度】，使用数字键盘输入75，然后选择参数单位%。

►3.2.7 设置直流偏移

• 将直流偏移电压改为1V，具体步骤如下：

依次点击屏幕波形区或按【Wave】→滑动波形菜单选【直流】，使用数字键盘输入1，然后选择参数单位V。

►3.2.8 设置噪声波

• 以设置幅度为500mVpp，直流偏移1V的噪声为例，具体步骤如下：

依次点击屏幕波形区或按【Wave】→【噪声】→【幅度】，使用数字键盘输入500，再选择参数单位mV，选【偏移】，使用数字键盘输入1，选择参数单位V。

3.3 辅助功能设置

辅助功能 (Utility) 可对通道设置、同步输出、频率计、系统、背光、语言、屏幕保护、关于 (版本信息) 等进行设置和查看。

功能菜单	功能子菜单	设定	说明
通道 1 设置 通道 2 设置	通道输出	关、开	/
	通道反向	关、开	/
	负载	50 Ω 、70 Ω 、高阻	1 Ω 至 9999 Ω
	幅度限制	关、开	/
	幅度上限	10.000 Vpp	设定通道幅度输出的上限值
	幅度下限	-10.000Vpp	设定通道幅度输出的下限值

- ①**通道输出**: 选择通道输出, 可选择“关”或“开”, 注意: 可通过按前面板上或屏幕的 CH1、CH2 键或快速开启通道输出。
- ②**通道反向**: 选择通道反向, 可选择“关”或“开”。

- ③**负载**:选择负载,可输入范围 1Ω 至 9999Ω,也可以选择 50Ω、高阻。
- ④**幅度限制**:支持幅度限制输出,以便保护负载;选择幅度限制,可选择“关”或“开”。
- ⑤**幅度上限**:选择幅度上限,设定幅度的上限范围。
- ⑥**幅度下限**:选择幅度下限,设定幅度的下限范围。

► 3.3.1 设置输出频率

功能菜单	功能子菜单	设定	说明
系统	同步输出	通道 1, 通道 2, 关	输出同步信号
	起始相位	独立、同步	/
	语言	English、简体中文	/
	声音	0%~100%	/
	分隔符	空格、逗号、无	/
	背光	5%~100%	/
	出厂设置	/	恢复出厂设置

依次选择 Utility→系统键,进入系统设置。

①**同步输出**:选择同步输出,可选择“CH1”、“CH2”和“关”。

②**起始相位**:选择起始相位,可选择“独立”和“同步”。独立:CH1 和 CH2 输出的相位没有关联;同步:CH1 和 CH2 输出的起始相位同步。

③**语言**:设置设备的系统语言,按下语言后可选择 English、简体中文。

④**声音**:设置按键时提示音大小。选择后滑动下方滑动条可调节 0% ~ 100%。

⑤**数字分隔符**:设置通道参数的数值之间分割符号,可选择逗号、空格、无。

⑥**背光**:设置屏幕显示的亮度,选择后滑动下方滑动条可调节 5% ~ 100%。

⑦**出厂设置**:恢复出厂设置选择。

►3.3.2 频率计

•本函数 / 任意波形发生器可以测量兼容 TTL 电平信号的频率及占空比,测量频率的范围为 100mHz~100MHz。使用频率计功能时,是通过外部数字调制或频率计接口 (INPUT/CNT/Sync 连接器) 输入兼容 TTL 电平的信号。

•依次选择 Utility→频率计,在参数列表中读取信号的“频率”、“周期”及“占空比”值。在没有信号输入时,频率计参数列表始终显示上一次测量的值,只有向外部数字调制或频率计接口 (INPUT/CNT/Sync 连接器) 输入兼容 TTL 电平的信号,频率计才刷新显示。

四、高级运用

本章介绍包括 AM, PM, FM, FSK, PSK, ASK 调制, 通过按 Mode 键进入调制, 再次按下 Mode 键则退出调制。

4.1 输出调制波形

▶4.1.1 幅度调制 (AM)

在幅度调制中, 已调制波形通常由载波和调制波组成, 载波的幅度将随着调制波的幅度的变化而变化。两个通道的调制模式相互独立, 您可以对通道一和通道二配置相同或不同的调制模式。

• 选择 AM 调制:

依次按【Mode】→【调幅】, 启用 AM 功能后, 设备以当前设置的调制波形和载波输出已调波形。

• 选择载波波形:

载波波形可以是: 正弦波、方波、斜波或任意波, 默认为正弦波。在选择 AM 调制后, 按【Wave】键进入载波波形选择界面。

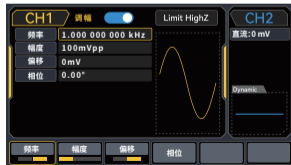
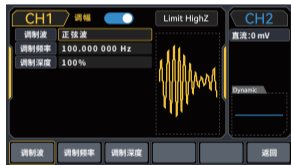

• 设置载波频率：

不同的载波波形,可设置的载波频率范围是不同的,载波的频率默认都为 1kHz,各载波的频率设置范围参见下表:

载波波形	功能菜单			
	TSG3020		TSG6020	
	最小值	最大值	最小值	最大值
正弦波	1 μ Hz	30MHz	1 μ Hz	60MHz
方波	1 μ Hz	24MHz	1 μ Hz	24MHz
斜波	1 μ Hz	20MHz	1 μ Hz	20MHz
脉冲波	1 μ Hz	24MHz	1 μ Hz	24MHz
任意波	1 μ Hz	10MHz	1 μ Hz	10MHz

• 选择调制波：

本产品的调制源来自内部,则调制波可以是:正弦波、方波、上升斜波、下降斜波、任意波、噪声,默认为正弦波。在您启用 AM 功能后,可以看到调制波默认为正弦波,若要进行更改,可以在启用调幅功能界面利用多功能旋钮或按“调制波”进行更改。

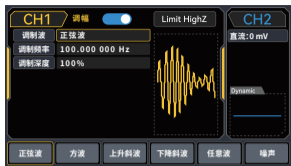

- » 方波: 占空比为 50%
- » 上升斜波: 对称度为 100%
- » 下降斜波: 对称度为 0%
- » 任意波: 4kpts长度DDS模式
- » 噪声: 白高斯噪声

• 设置调制频率:

设置调制波的频率, 范围为 2mHz~200kHz (默认为 100Hz)。在您启用 AM 功能后, 可以看到调制波频率默认为 100Hz, 若要进行更改, 可以在启用 AM 功能界面利用多功能旋钮进行更改, 或者按“调制频率”软键, 再通过数字键盘输入数字并按对应的单位软键来完成设置。

• 设置调制深度:

调制深度表示幅度变化的程度, 用百分比表示。AM 调制深度的可设置范围为 0%~120%, 默认为 100%。

- » 在调制深度设为 0% 时, 输出一个恒定的幅度 (为设置的载波幅度的一半)。
- » 在调制深度设为 100% 时, 输出幅度随着调制波形而变化。
- » 在调制深度设为大于 100% 时, 仪器的输出幅度不会超过 10Vpp (负载为 50Ω)。

若要进行更改, 可以在启用调幅功能界面利用多功能旋钮进行更改, 或者按“调制深度”软键, 再通过数字键盘输入数字并按对应的单位软键来完成设置。

• 综合实例:

首先让仪器工作于幅度调制 (AM) 模式, 然后设置设备内部的 200Hz 的正弦波作为调制信号和一个频率为10kHz、幅度为 200mVpp、占空比为 45% 的方波作为载波信号, 最后把调制深度设为 80%。

具体步骤如下:

(1) 启用幅度调制 (AM) 功能

依次按【Mode】→【调幅】来启用 AM。

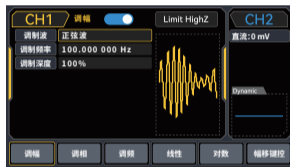

(2) 设置调制信号参数

接步骤(1), 【调制频率】键并使用数字键盘输入 200, 然后选择参数单位 Hz。

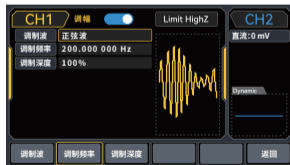

(3)设置载波信号波形和参数

按 Wave 键进入载波波形选择界面,选择方波作为载波(默认正弦波)。



点【频率】软键设置频率,使用数字键盘输入10,然后选择参数单位kHz;
点【幅度】软键设置幅度,使用数字键盘输入200,然后选择参数单位mVpp;
点【占空比】软键设置占空比,使用数字键盘输入45,然后选择参数单位%。
如右图所示。



(4)设置调制深度

载波参数设置完成后,依次按【Mode】→【调幅】软键,进入调幅设置;
点【调制深度】软键,再使用数字键盘输入80,然后选择参数单位%。

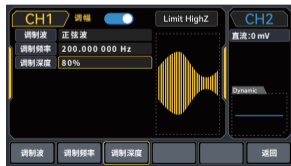

(5) 启用通道输出

按 CH1 键或点屏幕上输出标志, 灯亮表示已开启通道输出。

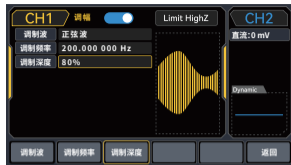

► 4.1.2 相位调制 (PM)

在相位调制中, 已调制波形通常由载波和调制波组成, 载波的相位将随着调制波的幅度的变化而变化。

• 选择 PM 调制:

依次按【Mode】→【调相】, 启用 PM 后, 设备以当前设置的调制波形和载波输出已调波形。

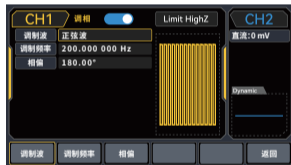

• 选择载波波形:

载波波形可以是: 正弦波、方波、斜波或任意波, 默认为正弦波。在选择 PM 调制后, 按【Wave】键进入载波波形选择界面。

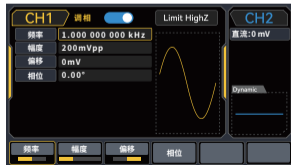

• 设置载波频率：

请参考 AM 载波频率。

• 选择调制波：

本产品的调制源来自内部，则调制波可以是：正弦波、方波、上升斜波、下降斜波、任意波、噪声，默认为正弦波。在您启用 PM 功能后，可以看到调制波默认为正弦波，若要进行更改，可以在启用调相功能界面利用多功能旋钮或按“调制波”进行更改。

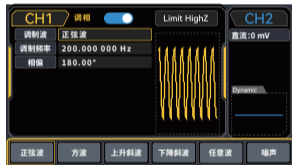

- » 方波: 占空比为 50%
- » 上升斜波: 对称度为 100%
- » 下降斜波: 对称度为 0%
- » 任意波: 选择任意波作为调制波形时, 函数 / 任意波形发生器通过自动抽点的方式将任意波长度限制为 4kpts
- » 噪声: 白高斯噪声

• 设置调制频率：

设置调制波的频率，范围为 2mHz~20kHz (默认为 100Hz)。在您启用 PM 功能后，可以看到调制波频率默认为 100Hz，若要进行更改，可以在启用 PM 功能界面利用多功能旋钮进行更改，或者按【调制频率】软键，再通过数字键盘输入数字并按对应的单位软键来完成设置。

• 设置相偏：

启动 PM 后，相位偏差表示已进行 PM 调制的波形的相位相对于载波相位的变化。PM 调制的相偏可设置范围为 $0^{\circ}\sim 360^{\circ}$ ，默认为 180° 。若要进行更改，可以在启用调相功能界面利用多功能旋钮和方向键的配合或按“相偏”进行更改。

• 综合实例：

首先仪器处于相位调制 (PM) 模式，然后设置内部的 200Hz 的正弦波作为调制信号和一个频率为 900Hz、幅度为 100mVpp 的正弦波作为载波信号，最后把相位偏差设为 200° 。具体步骤如下：

(1) 相位调制 (PM) 功能

依次按【Mode】→【调相】，启用 PM。

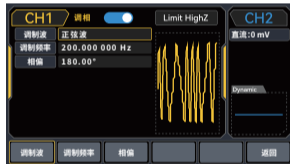

(2) 设置调制信号参数

接步骤 (1)，按【调制频率】软键并使用数字键盘输入 200，然后选择参数单位 Hz。

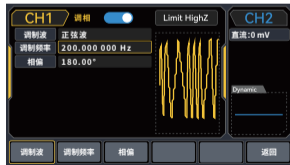

(3)设置载波信号波形和参数

按 Wave 键进入载波波形选择界面,选择方波作为载波(默认正弦波)。

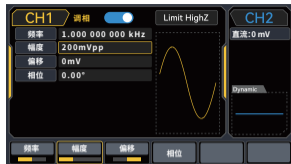

点【频率】软键设置频率,使用数字键盘输入 900,然后选择参数单位 Hz;
点【幅度】软键设置幅度,使用数字键盘输入 100,然后选择参数单位 mVpp。
如右图所示。

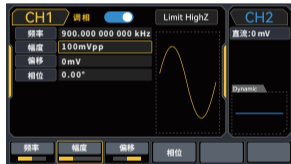

(4)设置相位偏差

载波参数设置完成后,按【Mode】→【调相】软键,进入调相设置:
按【相偏】软键再使用数字键盘输入 200,然后选择参数单位°。

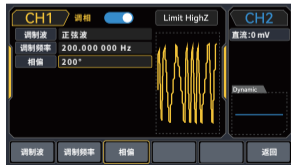

(5)启用通道输出

按 CH1 键, 灯亮表示已开启通道输出。

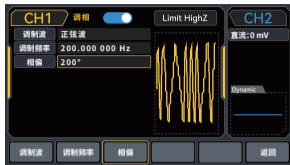

► 4.1.3 频率调制 (FM)

在频率调制中, 已调制波形通常由载波和调制波组成, 载波的频率将随着调制波的幅度的变化而变化。

• 选择 FM 调制:

依次按【Mode】→【调频】, 启用 FM 后, 仪器以当前设置的调制波形和载波输出已调波形。

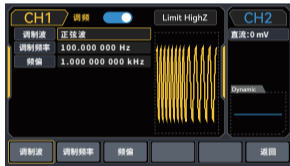

• 选择载波波形:

载波波形可以是: 正弦波、方波、斜波或任意波, 默认为正弦波。在选择 FM 调制后, 按【Wave】键进入载波波形选择界面。

• 设置载波频率:

请参考 AM 载波频率。

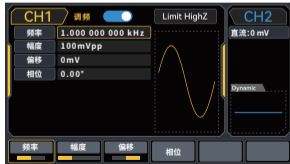

• 选择调制波：

本产品的调制源来自内部，则调制波可以是：正弦波、方波、上升斜波、下降斜波、任意波、噪声，默认为正弦波。在您启用 FM 功能后，可以看到调制波默认为正弦波，若要进行更改，可以在启用调频功能界面利用多功能旋钮或按“调制波”进行更改。

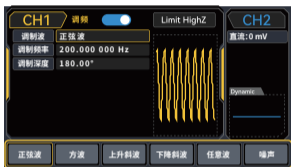

- » 方波：占空比为 50%
- » 上升斜波：对称度为 100%
- » 下降斜波：对称度为 0%
- » 任意波：选择任意波作为调制波形时，函数 / 任意波形发生器通过自动抽点的方式将任意波长度限制为 4kpts
- » 噪声：白高斯噪声

• 设置调制频率：

设置调制波的频率，范围为 2mHz - 200kHz (默认为 100Hz)。在您启用 FM 功能后，可以看到调制波频率默认为 100Hz，若要进行更改，可以在启用 FM 功能界面利用多功能旋钮进行更改，或者按“调制频率”软键，再通过数字键盘输入数字并按对应的单位软键来完成设置。

• 设置频偏：

频率偏差表示已进行 FM 调制的波形的频率相对于载波频率的偏差。FM 频偏的可设置范围为最小 DC 到最大当前载波带宽的一半，系统默认频偏为 1kHz。若要更改：启动 FM 后，按【频偏】软键进行更改。

- » 频率偏差 \leq 载波频率, 如果频偏值大于载波频率的值, 仪器自动将偏差值限制为当前载波频率所允许的最大值。
- » 频率偏差与载波频率之和 \leq 当前载波允许设置的最大频率, 如频偏值设置为一个无效值, 仪器自动将偏差值限制为当前载波频率所允许的最大值。

• 综合实例:

让仪器工作于频率调制 (FM) 模式, 然后设置来自仪器内部的 2kHz 的方波作为调制信号和频率为 10kHz、幅度为 100mVpp 的正弦波作为载波信号, 最后把频率偏差设为 5kHz。具体步骤如下:

(1) 启用相位调制 (FM) 功能

依次按【Mode】→【调频】, 启用 FM。

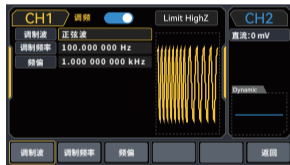

(2) 设置调制信号参数和波形

接步骤 1), 按【调制波】软键, 选择方波作为调制波形。再按【调制频率】软键, 并使用数字键盘输入 2, 然后选择参数单位 kHz。

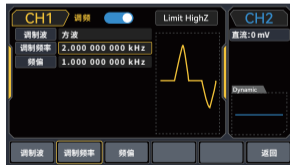

(3)设置载波信号波形和参数

按【Wave】键进入载波波形选择界面,再选择正弦波作为载波(默认为正弦波)。



点【频率】软键设置频率,使用数字键盘输入10,然后选择参数单位kHz;
点【幅度】软键设置幅度,使用数字键盘输入100,然后选择参数单位mV。



(4)设置频率偏差

载波参数设置完成后,按【Mode】→调频软键,进入调频设置:

按【频偏】软键,再使用数字键盘输入5,然后选择参数单位kHz。

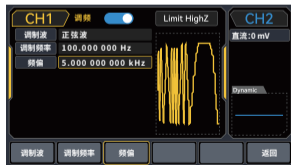

(5)启用通道输出

按 CH1 键, 灯亮表示已开启通道输出。

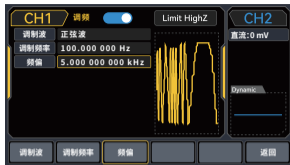

►4.1.4 频移键控 (FSK)

在频移键控中, 可以配置仪器在载波频率和跳跃频率之间的切换速率。

• 选择 FSK 调制:

依次按【Mode】→【频移键控】, 启用 FSK, 仪器以当前设置输出已调波形。

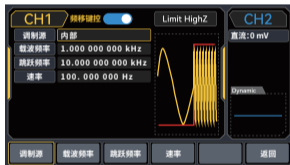

• 选择载波波形:

载波波形可以是: 正弦波、方波、斜波或任意波, 默认为正弦波。在选择 FM 调制后, 按【Wave】键进入载波波形选择界面。

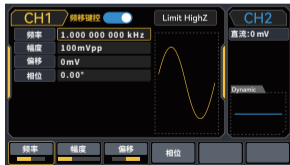

• 设置载波频率：

请参考 AM 载波频率。

• 选择调制源：

本产品可以选择来自内部或外部的调制源。启用 FSK 功能后，调制源默认为内部；如需更改，可以在启用频移键控功能界面利用多功能旋钮或依次按【调制源】→【外部】软键，调制源变为外部。

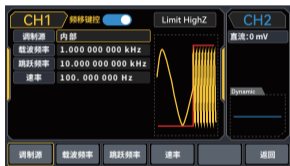

» 内部源:当调制源选择内部时,内部调制波是占空比为 50% 的方波(不可调),可通过设置 FSK 速率来指定载波频率与跳跃频率之间移动的频率。

» 外部源:当调制源选择外部时,将使用外部波形调制载波波形。FSK 输出频率由外部数字调制接口 (INPUT /CNT 接口) 上的逻辑电平决定。例如,外部输入逻辑低时,输出载波频率,外部输入逻辑高时,输出跳跃频率。

• 设置跳跃频率：

启用 FSK 功能后,可以看到跳跃频率默认为 10kHz,若要进行更改,可以在启用频移键控功能界面利用多功能旋钮和方向键的配合或按“跳跃频率”软键,再通过数字键盘输入数字并按对应的单位软键来完成设置。跳跃频率可设置的范围取决于载波波形,各载波的频率设置:请参考 AM 载波频率。

• 设置 FSK 速率:

当调制源选择为内部时,可以设置载波频率与跳跃频率之间切换频率。启用 FSK 功能后,可以对 FSK 速率设置(范围为 2mHz~100kHz),系统默认为 100Hz,若要进行更改,可以在启用频移键控功能界面利用多功能旋钮和方向键的配合或按“速率”软键,再通过数字键盘输入数字并按对应的单位软键来完成设置。

• 综合实例:

首先让仪器工作于频移键控(FSK)模式,然后设置一个内部的 2kHz、1Vpp 的正弦波作为载波信号,跳跃频率为 800Hz,让载波频率与跳跃频率以 200Hz 的频率切换。具体步骤如下:

(1) 启用 FSK 功能

依次按【Mode】→【频移键控】,启用 FSK。

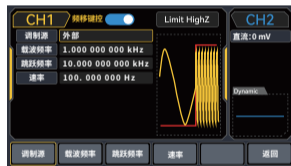

(2) 设置跳跃频率和调制速率

接步骤 1), 按【跳跃频率】软键, 并使用数字键盘输入 800, 然后选择参数单位 Hz。

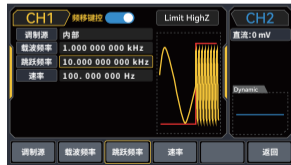

(3)设置调制速率

按【速率】软键,并使用数字键盘输入 200,然后选择参数单位 Hz。

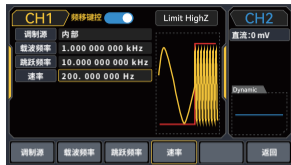

(4)设置载波信号

按【Wave】键进入载波波形选择界面,再选择正弦波作为载波(默认为正弦波)。



点【频率】软键设置频率,使用数字键盘输入 2,然后选择参数单位 kHz;

点【幅度】软键设置幅度,使用数字键盘输入 1,然后选择参数单位 Vpp;

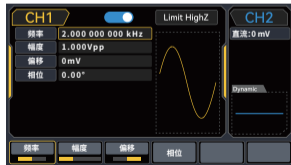

(5)启用通道输出

按 CH1 键, 灯亮表示已开启通道输出。



►4.1.5 幅移键控 (ASK)

幅移键控ASK中, 需要设定键控频率和载波频率, 其中键控频率就是已调制波形幅度跳变的频率。

• 选择 ASK 调制:

依次按【Mode】→【幅移键控】启用ASK。

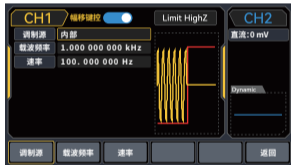

• 选择调制源:

支持内部和外部的调制源的调制波形。选择【调制源】设置“内部”或“外部”，默认为“内部”。

• 内部调制:

ASK 内部调制时, 调制波形为占空比为 50%的方波。

• 外部调制:

ASK 外部调制时, 信号发生器接收仪器前面板的【Aux In/Out】连接器输入的外调制信号。外调制信号必须为符合 TTL电平规范的方波。

• 速率:

可设置输出幅度在载波幅度和 0 之间切换的频率, 可通过数字键或触屏软键盘设置, 频率范围为 1mHz~1MHz, 默认为 100Hz。

• 综合实例:

请参考 FSK实例部分。

►4.1.6 相移键控 (PSK)

相移键控 PSK 中, 速率就是已调制波形相位跳变的频率, 调制相位默认为 180°。

• 选择 PSK 调制:

依次按【Mode】→【相移键控】启用PSK。

• 选择调制源:

支持内部和外部的调制源的调制波形。选择【调制源】设置“内部”或“外部”，默认为“内部”。

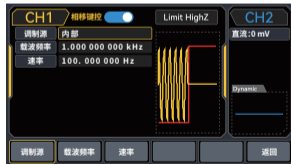

- **内部调制:**

PSK 内部调制时, 调制波形为占空比为 50%的方波。

- **外部调制:**

PSK 外部调制时, 信号发生器接收仪器前面板的【Aux In/Out】连接器输入的外调制信号。外调制信号必须为符合 TTL电平规范的方波。

- **速率:**

可设置输出相位跳变的频率, 通过数字键或触屏软键盘进行设置, 频率范围为 1mHz~1MHz, 默认为 100Hz。选择外部调制时, 无此参数设置

- **综合实例:**

请参考 FSK实例部分。

4.2 输出扫频波形

扫频模式下, 仪器在指定的扫频时间内, 以线性或对数方式输出波形。正弦波、方波、斜波和任意波 (DC 除外), 均可以产生扫频输出。

► 4.2.1 选择扫频

(1) 开启扫频功能

依次按【Mode】→【线性】, 启用扫频, 仪器将以当前设置输出扫频波形。

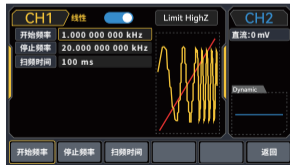

(2)选择扫频波形

扫频波形可以是：正弦波、脉冲波、斜波或任意波，默认为正弦波。在选择扫频后，按【Wave】键进入载波波形选择界面。

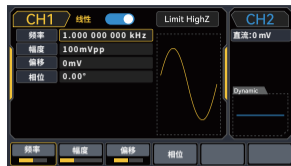

►4.2.2 设置起始和停止频率

起始频率和停止频率是频率扫描的频率上限和下限。函数 / 任意波形发生器总是从起始频率扫频到停止频率，然后又回到起始频率。依次按【Mode】→【线性】，进入扫频设置页面，此时可以利用多功能旋钮和方向键的配合或按【开始频率】或【停止频率】软键，再通过数字键盘输入数字并按对应的单位软键来完成设置。

- 当开始频率 < 停止频率时，DDS 函数发生器从低频向高频扫描。
- 当开始频率 > 停止频率时，DDS 函数发生器从高频向低频扫描。
- 当开始频率 = 停止频率时，DDS 函数发生器输出固定频率。

默认开始频率为 1kHz，停止频率为 20kHz，但不同的扫频波形起始和停止频率可设置的范围不同，各扫频的频率设置范围参见下表：

载波波形	频率			
	TSG3020		TSG6020	
	最小值	最大值	最小值	最大值
正弦波	1 μ Hz	30MHz	1 μ Hz	60MHz
方波	1 μ Hz	24MHz	1 μ Hz	24MHz
斜波	1 μ Hz	20MHz	1 μ Hz	20MHz
脉冲波	1 μ Hz	24MHz	1 μ Hz	24MHz
任意波	1 μ Hz	10MHz	1 μ Hz	10MHz

点【幅度】软键设置幅度,使用数字键盘输入1,然后选择参数单位Vpp;
 点【Duty】软键设置占空比,使用数字键盘输入50,然后选择参数单位% (占空比默认为50%)。

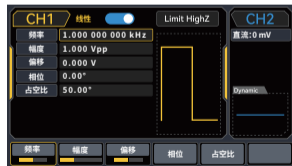

设置开始 / 停止频率、扫频时间：

按【Mode】软键，进入线性扫频：

点【开始频率】或【停止频率】软键，再使用数字键盘输入 1，然后选择参数单位 kHz。起始频率默认为 1kHz。

点【停止频率】软键，再使用数字键盘输入 50，然后选择参数单位 kHz。

点【扫频时间】软键，再使用数字键盘输入 2，然后选择参数单位 ms。

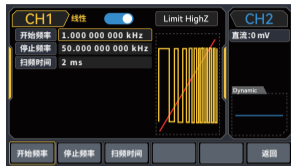

►4.2.3 扫频方式

按【Mode 键】，可以选择线性或对数：

- 线性：扫频期间波形发生器以线性方式改变输出频率；
- 对数：波形发生器以对数方式改变输出频率。

►4.2.4 扫频时间

启用扫频功能后，扫频时间（范围为 1ms~500s），系统默认为 100ms，若要进行更改，在扫频设置页面，按“扫频时间”软键，再通过数字键盘输入数字并按对应的单位软键来完成设置。

►4.2.5 综合实例

仪器在扫频模式下，设置一个幅度为 1Vpp、占空比为 50% 的方波信号作为扫频波，扫频方式设为线性，设置扫频时的开始频率为 1kHz、停止频率为 50kHz、扫频时间为 2ms，使用内部源触发输出扫频波。具体步骤如下：

(1) 启用线性扫频功能

依次按【Mode】→【线性】，启用线性扫频。

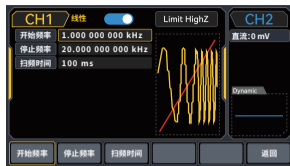

(2) 选择扫频波形

按【Wave】键进入扫频波形选择界面，再按选择方波（默认为正弦波）。



(3) 启用通道输出

按 CH1 键，灯亮表示已开启通道输出。



4.3 输出任意波形

本产品存储了 24 种任意波形,用户可以通过“波形文件”选择所需任意波形。

►4.3.1 启用任意波功能

依次按【Wave】→【任意波】软键,启用任意波功能,仪器以当前设置输出任意波。



►4.3.2 选择任意波

用户可以选择仪器内置的任意波形。启用任意波功能后,利用多功能旋钮和方向键的配合或【波形文件】软键来选择您需要的任意波。

内置任意波列表:

0	AmpALT	12	Log_up
1	AttALT	13	LogNormal
2	Cardiac	14	Lorentz
3	cosh	15	Pulseilogram
4	Dirichlet	16	Radar
5	EEG	17	sinc
6	EMG	18	SineVer
7	EOG	19	Stair down
8	Gauspuls	20	Stair up
9	Gmonopuls	21	Trapezia
10	Laplace	22	TV
11	Log_down	23	Voice

►4.3.3 模式选择

按【DDS】或按【逐点】可以切换DDS模式或逐点模式。

- DDS模式

在DDS输出模式下,参数设置方法参考正弦波信号,设备将以当前参数输出以DDS的方式输出您所选择的任意波形。

- 逐点模式

在逐点输出模式下,用户可以设置采样率(每秒输出点数)或者频率,其他参数设置方法参考正弦波信号,设备将以当前参数输出以逐点的方式输出您所选择的任意波形。

五、故障处理

下面列举仪器在使用过程中可能出现的故障及排查方法,请按照相应的步骤进行处理,如不能处理,请与经销商或当地办事处联系,同时请提供机器的设备信息(获取方法:依次按 Utility→系统→关于)。

5.1 屏幕无显示(黑屏)

如果按下侧面板电源开关信号发生器仍然黑屏,没有任何显示:

- ①检查电源是否接好。

- ②检查后面板的电源开关是否接好和置“1”。
- ③前面板的电源开关是否接好。
- ④重新启动仪器。
- ⑤如果仍然无法正常使用本产品,请与经销商或当地办事处联系,让我们为您服务。

5.2无波形输出

设置正确但没有波形输出:

- ①检查 BNC 电缆与通道输出端是否正确连接。
- ②检查按键 CH1 或 CH2 是否打开。
- ③如果仍然无法正常使用本产品,请与经销商或当地办事处联系,让我们为您服务。

六、维护保养

一般保养

- 请勿把仪器储存或放置在液晶显示器会长时间受到直接日照的地方。
- 为避免损坏仪器或连接线,请勿将其置于雾气、液体或溶剂中。

清洁维护

- 请根据使用情况经常对仪器进行清洁。
- 先断开电源,然后用潮湿但不滴水的软布(可使用柔和的清洁剂或清水擦拭仪器外部的浮尘,不要使用含苯,二甲苯,二甲苯和丙酮等烈性物质的化学药品或清洁剂)。
- 清洁带有液晶显示屏的仪器时,请注意不要划伤 LCD 保护屏。
- 请勿使任何腐蚀性的液体沾到仪器上,以免损坏仪器。

! **警告:**在重新通电使用前,请确认仪器已经干透,避免因水分造成电气短路甚至人身伤害。

七、生产信息

产品名称:函数信号发生器

品牌/型号:TSG3020/TSG6020

生产商:深圳市菲尼瑞斯科技有限公司

地址:广东省深圳市龙华区大浪街道伟华达工业园C栋西侧8楼

服务热线:0755-28020752

服务邮箱: support@fnirsi.com

商务邮箱: business@fnirsi.com

官方网站: www.fnirsi.cn

执行标准: GB/T 9317-2012

八、保修说明

※此页为保修卡基本凭证, 请妥善保管

感谢您选择本公司产品, 本产品自销售之日起计保修期。在产品保修期内, 凡按照产品使用, 说明书安装使用。于正常环境、条件使用之下, 因原物料及加工过程中之瑕疵而导致故障, 可依据本保修条款的内容享受无偿维修服务, 本保修卡请用户妥善保管, 以作保修凭证, 丢失恕不补发。

以下情况将实施有偿维修服务:

- 1.不能出示有效保修卡原件;
- 2.产品安装不符合产品要求、标准和相关规范造成的损坏;
- 3.产品安装环境中相关配件不符合产品要求、标准和相关规范造成的损坏;
- 4.用户对产品使用不当、保管不妥或擅自拆机、私自维修等原因造成的损坏;
- 5.超过保修期。

附录 A、出厂重置状态

载波波形	
当前载波	正弦波
输出负载	HighZ
同步输出	关
通道输出	关
通道输出反相	关
幅度限止	关
幅度上限	+10V
幅度下限	-10V
基本波	
频率	1kHz

幅度	100mVpp
直流偏移	0mV
起始相位	0°
方波占空比	50%
斜波对称度	100%
脉冲波占空比	50%
脉冲波上升沿	12ns
脉冲波下降沿	12ns
任意波	
内建任意波	AbsSine
AM 调制	
调制源	内部

调制波	正弦波
调制频率	100Hz
调制深度	100%
FM 调制	
调制源	内部
调制波	正弦波
调制频率	100Hz
频偏	1kHz
PM 调制	
调制源	内部
调制波	正弦波
调相频率	100Hz

相偏	180°
FSK 调制	
调制源	内部
FSK 速率	100Hz
跳跃频率	2MHz
扫频	
扫频类型	线性
起始频率	1kHz
停止频率	20kHz
扫频时间	100ms
系统参数	
蜂鸣器声音	最大

数字分隔符	,
背光	100%
语言	取决于出厂设置

附录 B、性能指标

除非另有说明,所有技术指标规格在以下两个条件成立时均能得到保证。

- ①信号发生器处于校准周期内并执行过校准。
- ②信号发生器在规定的操作温度(18°C 至 28°C)内连续运行 30 分钟以上。

除标有“典型值”字样的规格以外,所有规格都有保证。

型号	TSG3020	TSG6020
通道	2 通道	2 通道
最高频率	30MHz	60MHz

采样率	200MSa/s	
波形	正弦波、方波、斜波、脉冲波、噪声、直流 DC、任意波形	
工作模式	输出选通、持续、调制、频率扫描	
调制类型	AM、FM、PM、FSK、ASK、PSK、Line、Log	
波形特征		
正弦波		
频率范围	1 μ Hz~30MHz	1 μ Hz~60MHz
分辨率	1 μ Hz	
准确度	90 天内 \pm 50ppm, 1 年内 \pm 100ppm (18°C 至 28°C)	
谐波失真 (典型值)	DC~5MHz	- 60dBc

谐波失真(典型值)	5MHz~30MHz:	- 50dBc
	30MHz~60MHz:	- 40dBc
总谐波失真(典型值)	<0.2% (DC~20kHz, 1Vpp)	
寄生信号(非谐波, 典型值)	DC~10MHz, < - 70dBc	
	> 10MHz < - 70dBc + 6dB / 倍频程	
相位噪声(典型值)	10 MHz: \leq - 125 dBc/Hz (典型值, 0dBm, 10kHz 偏移)	
方波		
频率范围	1 μ Hz~24MHz	1 μ Hz~24MHz
分辨率	1 μ Hz	
上升 / 下降时间	13.5ns (典型值, 1kHz, 1Vpp)	
过冲(典型值)	\leq 1%	
占空比	0.01%~99.99% (受当前频率设置限制)	

对称性(在50%占空比下)	1ns+周期的100ppm	
抖动(典型值)	典型值(1MHz,1Vpp,50Ω)	
	≤5MHz: 2ppm + 200ps	
	>5MHz: 200ps	
斜波		
频率范围	1μHz – 20MHz	1μHz – 20MHz
分辨率	1μHz	
非线性度	3%±2 mV(典型值,1kHz,1Vpp,对称性50%)	
对称性	0.0% 至 100.0%(受当前频率设置限制)	
脉冲波		
频率范围	1μHz - 24MHz	1μHz - 24MHz
分辨率	1μHz	

脉冲宽度	$\geq 17\text{ns}$	
可变边沿	$\geq 12\text{ns}$	$\geq 12\text{ns}$
过冲(典型值)	$\leq 2\%$ (典型值 1Vpp)	
抖动	150ps	
高斯噪声		
带宽	30MHz 带宽 (-3dB) (典型值)	60MHz 带宽 (-3dB) (典型值)
直流偏移	9.999V	
范围(峰值 AC + DC)	$\pm 5\text{V}$ (50 Ω)	$\pm 10\text{V}$ (高阻)
偏移精度	偏置设置值的 $\pm 3\%$ \pm 幅度设置值的 $6\% \pm 2\text{mV}$	
任意波形特征		
频率范围	1 μHz - 10MHz	1 μHz - 10MHz
分辨率	1 μHz	

波形长度	4kpts	
垂直分辨率	14bits (包括符号)	
采样率	200MSa/s	
最小上升 / 下降时间	< 20ns 典型值	< 20ns 典型值
抖动	DDS模式: 5ns±150ps; 逐点模式: ±150ps	
非易失存储	24个波形	
输出特性		
幅度范围	≤10MHz: 1mVpp - 10Vpp; (50Ω)	≤60MHz: 1mVpp - 5Vpp; (50Ω)
精度 (1kHz 正弦波)	±(设置值的 5% + 2mVpp)	
幅度平坦度 (相对于 1kHz 正弦波, 1Vpp/50Ω)	测试条件: 典型值 (正弦波, 2.0Vpp) ≤100kHz : ±0.1dB ≤20MHz : ±0.3dB ≤30MHz : ±0.5dB ≤40MHz : ±0.6dB ≤60MHz : ±0.8dB	

波形输出

阻抗	50Ω 典型值
绝缘	到地线最大 42Vpk
保护	通道保护

调制类型

AM调制		FM调制	
载波	正弦、方波、斜波、任意波	载波	正弦、方波、斜波、任意波
调制波	正弦、方波、斜波、噪声、任意波	调制波	正弦、方波、斜波、噪声、任意波
调制频率	2mHz - 200kHz	调制频率	1μHz - 200kHz
调制深度	0% - 120%	频偏	DC - 15MHz (UTG932) DC - 30MHz (UTG962)

调制类型			
PM调制		FSK调制	
载波	正弦、方波、斜波、任意波	载波	正弦、方波、斜波、任意波
调制波	正弦、方波、斜波、噪声、任意波	源	内部 / 外部
调制频率	2mHz - 200kHz	调制波	50% 占空比的方波
相偏	0° - 360°	速率	2mHz - 100kHz

扫频	
载波	正弦、方波、斜波、任意波
类型	线性、对数
扫频时间	1ms - 500s±0.1%
同步信号	

输出电平	TTL 兼容
输出频率	1 μ Hz - 2MHz
输出阻抗	50 Ω , 典型值
耦合方式	直流
触发输入	
输入电平	TTL 兼容
输入阻抗	>10k Ω , DC 耦合
频率计	
输入电平	TTL 兼容
输入频率范围	100mHz - 100MHz
精度	\pm 51ppm
频率分辨率	7 位

耦合方式	直流
一般技术规格	
显示	
显示类型	4.3 寸 TFT LCD
显示分辨率	480 水平 × 272 垂直
电源电压	DC5V, 2A
耗电	小于 10W
环境	
温度范围	操作: 10°C - +40°C
	非操作: -20°C - +60°C
冷却方法	自然冷却
湿度范围	+35°C 以下: ≤90% 相对湿度

湿度范围	+35°C - +40°C: ≤60% 相对湿度
海拔高度	操作2000 米以下
	非操作15000 米以下
机械规格	
尺寸(参考数据)	172mm×90mm×68mm
净重	≈732.6g
毛重	≈1191g

附录 C、配件清单

型号	TSG6000
标配	一支符合所在国标准的电源适配器
	一根 BNC 转鳄鱼夹电缆
	一根 BNC 电缆 (1 米)
	一份产品保修卡



电源适配器:

电源电压	100 - 240Vrms , 50/60Hz , 0.4A
输出电压	5VDC
输出电流	2A



1. SAFETY INFORMATION

1.1 Safety Terms and Symbols

The following terms may appear in this manual:

-  **Warning:** Indicates conditions or actions that could result in serious injury or death.
-  **Caution:** Indicates conditions or actions that could result in damage to the product or other property.

The following terms may appear on the product:

-  **Danger:** Indicates that performing the action could cause personal injury.
-  **Warning:** Indicates that performing the action may be hazardous.
-  **Caution:** Indicates that performing the action may cause damage to this product or to devices connected to it.

1.2 General Safety Summary

This product is designed and manufactured in strict accordance with the safety requirements of GB4793 for electronic measuring instruments and the international standard IEC 61010-1. It complies with CAT I 300V overvoltage insulation standard and Pollution Degree 1. Please read the following safety precautions carefully:

- To prevent electric shock or fire, only use the dedicated power cord and adapter approved for use in your country or region.
- This product is grounded through the protective earth conductor in the power cord.
- To avoid electric shock, ensure the power outlet is properly grounded before use.
- Before connecting any input or output terminals other than the power cord, ensure that the protective ground terminal is reliably connected to the power ground. To avoid personal injury and prevent equipment damage, only qualified personnel should service the device.
- To prevent fire or electric shock hazards, always follow the rated operating range and product markings.
- Operation outside the rated limits is strictly prohibited.
- Before use, inspect all accessories for mechanical damage. Do not use damaged accessories and replace them promptly.
- Only use accessories supplied with this product.
- Do not insert metallic objects into input or output terminals.
- If the product is suspected to be damaged, have it inspected by qualified service personnel.
- Do not operate the product with the case open.
- Do not operate in a humid environment.
- Keep the product surface clean and dry.

2. PRODUCT OVERVIEW

2.1 Main Features

- Dual channels, maximum output frequency of 60MHz / 30MHz, and maximum output amplitude of 20Vpp.
- High-precision DDS (Direct Digital Synthesis) technology with 200MSa/s sampling rate and 14-bit vertical resolution.
- Utilizes innovative **ZeroSurge** technology for reduced overshoot, faster edges, and higher accuracy in square/pulse/ramps. Duty cycle, pulse width, edge time, and symmetry are finely adjustable.
- Utilizes innovative **VeriPoint** technology to output arbitrary waveforms point by point, delivering low-jitter signals within a 4Kpts length using a continuously variable sampling rate from 1Sa/s to 200MSa/s, while preserving every waveform detail.
- 7-digit high-precision frequency counter compatible with TTL-level signals.
- Supports storage of 24 sets of non-volatile digital arbitrary waveforms.
- Rich analog and digital modulation capabilities: AM, FM, PM, ASK, PSK, FSK.
- Frequency sweep output supported.
- 4.3” TFT-LCD touchscreen with dual operation modes: touch and keypad.
- Standard interfaces include USB Device and Type-C power input; supports mobile power banks for field testing scenarios.

2.2 Output Characteristics

Channel	CH1, CH2
Amplitude Range	2mVpp~20Vpp(High Impedance, <10MHz) / 2mVpp~10Vpp(High Impedance, >10MHz) / 1mVpp~10Vpp(50Ω, <10MHz) / 1mVpp~5Vpp(50Ω, >10MHz)
Waveforms	Sine, Square, Pulse, Ramp, Arbitrary, Noise, DC
Modulation	AM, FM, PM, ASK, PSK, FSK
Sweep	Linear Sweep, Logarithmic Sweep

2.3 Front Panel and Key Descriptions

► 2.3.1 Front Panel

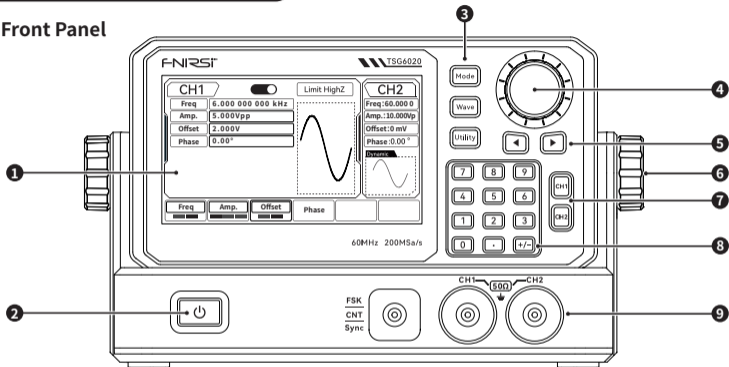

- ① **Display Screen:** 4.3-inch high-resolution TFT color LCD. The screen uses distinct color tones to clearly differentiate the status of Channel 1 and Channel 2 outputs, function menus, and other key information.
- ② **Power Switch:** When the device is powered on, the power button's indicator light is illuminated. Long press to turn off the device.

- ③ **Function Keys:** Include Mode, Wave, and Utility. These keys are used to configure modulation settings, select base waveforms, and access auxiliary functions.
- ④ **Multifunction Knob/Button:** Rotate the multifunction knob to change numeric values (clockwise to increase), or use it as a directional control. Press the knob to select functions or confirm parameter settings.
- ⑤ **Direction Keys:** Used in conjunction with the multifunction knob to shift the digit position when setting parameters.
- ⑥ **Adjustable Screen Angle Knob:** Allows adjustment of the screen viewing angle for user comfort. The screen can be rotated up to 90°.
- ⑦ **CH1/CH2 Channel Output Control Buttons:** Quickly toggle the active channel displayed on screen. Enable or disable output with a single press. When output is enabled, the button's backlight is on and the information label displays the output function (including advanced modes if enabled). When disabled, the backlight turns off and the output is shut down.
- ⑧ **Numeric Keypad:** Includes number keys (0–9), decimal point (.), and sign key (+/-) for direct parameter input.
- ⑨ **Output Ports (Left to Right):** "From left to right: Sync Output / Frequency Counter Input, CH1 Output Connector, CH2 Output Connector. The Frequency Shift Keying (FSK), Sync Signal, and Frequency Counter share the same port."

⚠ Note:

- The channel output terminals are equipped with overvoltage protection. Protection is triggered if any of the following conditions are met:

- When the output amplitude is set above 250mVpp and the input voltage exceeds $|\pm 12.5V|$ at frequencies below 10kHz.
- When the output amplitude is set at or below 250mVpp and the input voltage exceeds $|\pm 2.5V|$ at frequencies below 10kHz.
- When overvoltage protection is triggered, the channel output will automatically shut off.

► 2.3.2 Rear Panel

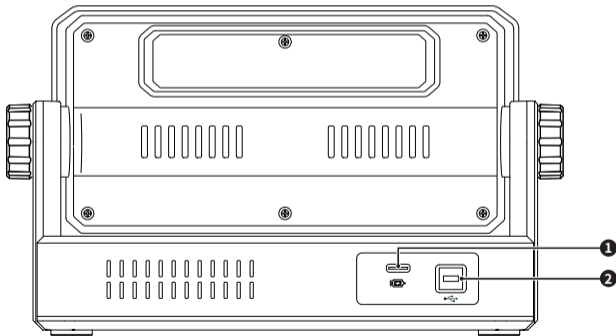

- ① **Power Interface:Rated output:** 5V, 2A. For optimal signal-to-noise ratio performance, it is recommended to use the official standard power adapter.
- ② **USB Interface:**Used to connect to a host computer via USB for remote communication.

►2.3.3 User Interface

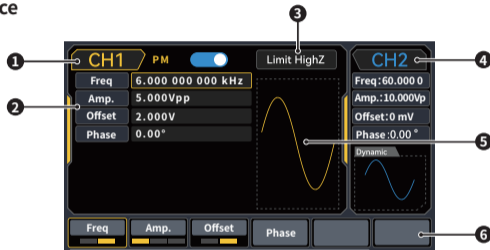

- ① **CH1 Output Switch:**Click to enable Channel 1 output. When the button turns blue, the output is active.
- ② **Waveform Parameter List:**Displays various parameters of the current waveform in list form. If a parameter is highlighted with a yellow border, it can be adjusted using the soft menu keys, numeric keypad, direction keys, or multifunction knob. When a character's background color matches the current channel color, it indicates the parameter is in edit mode and can be modified using the direction keys, numeric keypad, or multifunction knob.

- ③ **Load Information:** “Limit HighZ” indicates that the output impedance is set to high impedance (adjustable from 1Ω to 99999Ω ; default is high impedance). Tap this field to quickly access the load setting interface.
- ④ **CH2 Collapsed View:** When a channel’s information is collapsed, this area will scroll and display waveform output information. Click the “CH2” label or the waveform display area to expand the settings interface for the current channel. The expanded settings are configured the same way as described above.
- ⑤ **Waveform Display Area:** Shows the waveform shape currently set for the channel. The waveform color indicates which channel it belongs to. The parameter list on the left displays values related to the waveform. Tap this area to quickly switch waveform types. Note: When accessing system settings, the waveform display area is hidden and replaced with an extended parameter list.
- ⑥ **Softkey Labels:** These are software menu buttons for waveform selection and menu operations. A yellow selection box indicates the currently selected item.

3. GETTING STARTED

3.1 General Inspection

When receiving a brand-new unit, it is recommended to inspect the instrument following the steps below.

► 3.1.1 Shipping and Appearance Check

- If the packaging box or foam padding appears to be seriously damaged, contact your distributor or the local office of the manufacturer.
- If the instrument is damaged due to transportation, please retain the packaging and notify the shipping company and distributor. The distributor will arrange for repair or replacement.

► 3.1.2 Check Accessories

- Accessories include: power adapter, one BNC cable (1m), one BNC-to-alligator clip cable, and a product warranty card.
- If any accessory is missing or damaged, contact your distributor or the local office of the manufacturer.

► 3.1.3 Inspect the Instrument

- If the instrument appears physically damaged, does not operate properly, or fails the performance test, contact your distributor or the local office of the manufacturer.

3.2 Outputting Basic Waveforms

► 3.2.1 Setting Sine Wave Output Frequency

The default waveform configuration is a 1kHz sine wave with 100mV Vpp

To change the frequency to 1MHz:

Tap the waveform display area or press **[Wave]** → **[Sine]** → **[Frequency]**, then use the numeric keypad to input "1" and select the unit "MHz".

▶ 3.2.2 Setting Sine Wave Amplitude

The default Vpp amplitude is 100mV.

To set the amplitude to 1Vpp:

Tap the waveform area or press **[Wave]** → **[Sine]** → **[Amplitude]**, enter "1" using the numeric keypad, and select the unit "Vpp".

▶ 3.2.3 Setting Sine Wave Offset Voltage

The default offset voltage is 0V.

To set the offset voltage to -150mV:

Tap the waveform area or press **[Wave]** → **[Sine]** → **[Offset]**, enter "-150" using the numeric keypad, and select the unit "mVpp".

※ Note: This parameter can also be adjusted using the multifunction knob and arrow keys.

▶ 3.2.4 Setting Phase

The default phase is 0°. To set the phase to 90°, press the **[Phase]** button, enter "90" using the numeric keypad, and select the appropriate unit.

► 3.2.5 Setting Pulse Wave Duty Cycle

The default pulse wave has a frequency of 1MHz and a duty cycle of 50%. To set the duty cycle to 25%: Tap the waveform area or press **[Wave]** → **[Pulse]** → **[Duty Cycle]**, enter "25" using the numeric keypad, and select the unit "%".

► 3.2.6 Setting Ramp Wave Symmetry

The default ramp wave frequency is 1kHz. To set the symmetry to 75% for a triangle wave:

Tap the waveform area or press **[Wave]** → **[Ramp]** → **[Symmetry]**, enter "75" using the numeric keypad, and select the unit "%".

► 3.2.7 Setting DC Offset

To set the DC offset to 1V:

Tap the waveform area or press **[Wave]** → swipe the waveform menu to select **[DC]**, then input "1" using the numeric keypad and select the unit "V".

► 3.2.8 Setting Noise Wave

To set a noise waveform with 500mVpp amplitude and 1V DC offset:

Tap the waveform area or press **[Wave]** → **[Noise]** → **[Amplitude]**, enter "500" and select the unit "mV"; then select **[Offset]**, enter "1", and select the unit "V".

3.3 Utility Function Settings

The Utility menu allows you to configure and view settings for channel output, sync output, frequency counter, system settings, backlight, language, screen saver, and device information (version info).

Function Menu	Submenu	Settings	Description
Channel 1 Settings Channel 2 Settings	Channel Output	Off, On	/
	Channel Invert	Off, On	/
	Load	50 Ω , 70 Ω , High-Z	1 Ω ~ 9999 Ω
	Amplitude Limit	Off, On	/
	Amplitude Upper Limit	10.000 Vpp	Sets the upper limit for channel amplitude output
	Amplitude Lower Limit	-10.000 Vpp	Sets the lower limit for channel amplitude output

① **Channel Output:** Choose whether to enable or disable the channel output. Note: You can also toggle output quickly using the CH1/CH2 buttons on the front panel or touchscreen.

② **Channel Inversion:** Set to “Off” or “On” to disable or enable waveform inversion for the selected channel.

- ③ **Load:** Selectable from fixed impedances (50Ω, High-Z) or custom values ranging from 1Ω to 9999Ω.
- ④ **Amplitude Limit:** When enabled, limits the output amplitude to protect the load; can be set to "On" or "Off".
- ⑤ **Amplitude Upper Limit:** Sets the maximum output amplitude for the channel.
- ⑥ **Amplitude Lower Limit:** Sets the minimum output amplitude for the channel.

► 3.3.1 System Settings

Function Menu	Submenu	Settings	Description
System	Sync Output	Channel 1, Channel 2, Off	Output sync signal
	Start Phase	Independent, Synchronized	/
	Language	English, Simplified Chinese	/
	Volume	0%~100%	/
	Separator	Space, Comma, None	/
	Backlight	5%~100%	/
	Factory Reset	/	Restore factory settings

Navigate to Utility → System to enter the system settings.

- ① **Sync Output:** Select the source of the sync signal. Options include “CH1,” “CH2,” or “Off.”
- ② **Initial Phase:** Select whether CH1 and CH2 start with independent or synchronized phase.
Independent: CH1 and CH2 phases are not linked. Synchronized: CH1 and CH2 start with the same initial phase.
- ③ **Language:** Set the system language. Options include English and Simplified Chinese.
- ④ **Volume:** Adjust the keypress sound volume. Use the slider to adjust from 0% to 100%.
- ⑤ **Number Separator:** Set the delimiter for numeric values. Options include comma, space, or none.
- ⑥ **Backlight:** Adjust the screen brightness. Use the slider to adjust from 5% to 100%.
- ⑦ **Factory Reset:** Restore all settings to factory defaults.

► 3.3.2 Frequency Counter

- The function/arbitrary waveform generator can measure the frequency and duty cycle of TTL-compatible signals, within a frequency range of 100 mHz to 100 MHz. The frequency counter function works via the INPUT/CNT/Sync connector. A TTL-compatible signal must be applied to this input.
- Navigate to Utility → Counter to view measurements of Frequency, Period, and Duty Cycle. If no signal is connected, the last measured values remain displayed. The counter updates only when a TTL-level signal is applied.

4. ADVANCED FUNCTIONS

This chapter introduces modulation functions including AM, PM, FM, FSK, PSK, and ASK. Press the Mode key to enter modulation mode; press it again to exit.

4.1 Output Modulated Waveforms

► 4.1.1 Amplitude Modulation (AM)

In amplitude modulation, the modulated waveform typically consists of a carrier wave and a modulation wave. The amplitude of the carrier varies according to the modulation signal. Modulation modes for CH1 and CH2 are independent, and you may configure the same or different modulation types for each channel.

- **Select AM modulation:**

Press [Mode] → [AM]. Once AM is enabled, the device outputs the modulated waveform based on the current modulation and carrier settings.

- **Select the carrier waveform:**

The carrier waveform can be sine, square, ramp, or arbitrary. The default is sine. After entering AM modulation mode, press the [Wave] key to access carrier waveform settings.



• **Set carrier frequency:**

The available frequency range varies depending on the selected carrier waveform. The default frequency is 1kHz. See the table below for details:

Carrier Waveform	Function Menu			
	TSG3020		TSG6020	
	Min	Max	Min	Max
Sine	1 μ Hz	30MHz	1 μ Hz	60MHz
Square	1 μ Hz	24MHz	1 μ Hz	24MHz
Triangle	1 μ Hz	20MHz	1 μ Hz	20MHz
Pulse	1 μ Hz	24MHz	1 μ Hz	24MHz
Arbitrary	1 μ Hz	10MHz	1 μ Hz	10MHz

• **Select modulation waveform:**

When using the internal modulation source, the available modulation waveforms include: sine, square, rising ramp, falling ramp, arbitrary, and noise. The default waveform is sine. After AM is enabled, the modulation waveform defaults to sine. To change it, use the multifunction knob or press "Mod Wave" on the AM modulation screen.

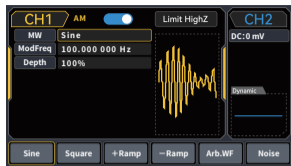

- » Square wave: Duty cycle 50%
- » Rising ramp: Symmetry 100%
- » Falling ramp: Symmetry 0%
- » Arbitrary wave: 4kpts length DDS mode
- » Noise: White Gaussian noise

• Set modulation frequency:

Sets the modulation wave frequency, ranging from 2 mHz to 200 kHz (default is 100 Hz). After enabling the AM function, the modulation frequency defaults to 100 Hz. To change it, use the multifunction knob in the AM function interface or press the “Mod Freq” softkey, then enter numbers via the numeric keypad and select the corresponding unit to complete the setting.

• Set modulation depth:

Modulation depth indicates the degree of amplitude change, shown as a percentage. The AM modulation depth can be set from 0% to 120%, with 100% as the default.

- » When the depth is 0%, a constant amplitude signal is output (equal to half the carrier amplitude).
- » When the depth is 100%, the amplitude varies linearly with the modulation wave.
- » If the depth exceeds 100%, the output amplitude does not exceed 10 Vpp (with a 50Ω load).

To adjust the depth, use the multifunction knob in the AM modulation interface or press the “Mod Depth” softkey, then enter values via the numeric keypad and select the corresponding unit to finish.

• **Comprehensive example:**

First, set the instrument to operate in Amplitude Modulation (AM) mode. Then set a 200 Hz sine wave inside the device as the modulation signal and a square wave with a frequency of 10 kHz, amplitude of 200 mVpp, and duty cycle of 45% as the carrier signal. Finally, set the modulation depth to 80%.

The specific steps are as follows:

(1) Enable amplitude modulation (AM) function

Press **[Mode]** → **[Amplitude Modulation]** sequentially to enable AM.

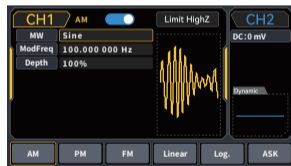

(2) Set modulation signal parameters

Following step (1), press the **[Modulation Frequency]** button, input 200 using the numeric keypad, then select the unit Hz.



(3) Set carrier signal waveform and parameters

Press the Wave key to enter the carrier waveform selection screen. Select Square wave as the carrier (default is Sine wave).

Tap the **[Frequency]** soft key to set the frequency, enter 10 using the numeric keypad, then select the unit kHz.

Tap the **[Amplitude]** soft key to set the amplitude, enter 200 using the numeric keypad, then select the unit mVpp.

Tap the **[Duty Cycle]** soft key to set the duty cycle, enter 45 using the numeric keypad, then select the unit %.

As shown in the image on the right.

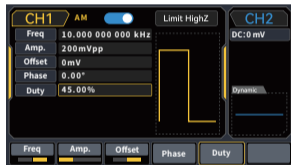

(4) Set modulation depth

After setting the carrier parameters, press **[Mode]** → **[AM]** soft key to enter the amplitude modulation settings.

Tap the **[Modulation Depth]** soft key, enter 80 using the numeric keypad, then select the unit %.



(5) Enable channel output

Press the CH1 button or tap the output icon on the screen; the light indicates the channel output is enabled.

► 4.1.2 Phase Modulation (PM)

In phase modulation, the modulated waveform usually consists of a carrier and a modulation wave, where the carrier's phase varies with the amplitude of the modulation wave.

• Select PM modulation:

Press **[Mode]** → **[Phase Modulation]** sequentially. After enabling PM, the device outputs the modulated waveform using the current modulation and carrier settings.

• Select carrier waveform:

The carrier waveform can be sine, square, ramp, or arbitrary wave, with sine wave as the default. After selecting PM modulation, press the **[Wave]** key to enter the carrier waveform selection screen.

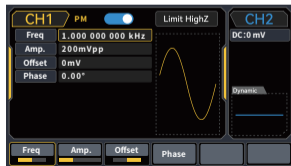
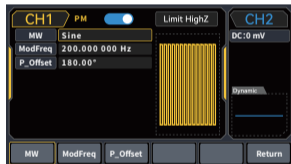

- **Set carrier frequency:**

Please refer to the AM carrier frequency.

- **Select modulation wave:**

The modulation source is internal. The modulation wave can be sine, square, rising ramp, falling ramp, arbitrary wave, or noise, with sine wave as the default. After enabling the PM function, the modulation wave defaults to sine wave. To change it, use the multifunction knob or press “Modulation Wave” in the phase modulation settings screen.

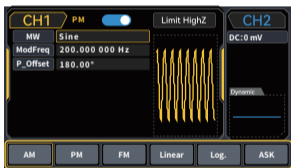

- » Square wave: Duty cycle 50%

- » Rising ramp: Symmetry 100%

- » Falling ramp: Symmetry 0%

- » Arbitrary wave: When selected as the modulation wave, the function/arbitrary waveform generator limits the arbitrary wave length to 4kpts using automatic sampling.

- » Noise: White Gaussian noise

- **Set modulation frequency:**

Set the frequency of the modulation wave, ranging from 2 mHz to 20 kHz (default is 100 Hz). After enabling the PM function, the modulation frequency defaults to 100 Hz. To change it, use the multifunction knob in the PM settings screen or press the **[Modulation Frequency]** soft key, then enter the value using the numeric keypad and select the unit soft key to complete the setting.

- **Set phase offset:**

After enabling PM, the phase offset represents the phase difference between the PM modulated waveform and the carrier phase. The phase offset range is 0° to 360° , with a default of 180° . To change it, use the multifunction knob combined with the arrow keys or press “Phase Offset” in the PM settings screen.

- **Comprehensive example:**

First, set the instrument to Phase Modulation (PM) mode. Then set an internal 200 Hz sine wave as the modulation signal and a 900 Hz sine wave with 100 mVpp amplitude as the carrier signal. Finally, set the phase offset to 200° . The specific steps are as follows:

- (1) **Phase Modulation (PM) function**

Press **[Mode]** → **[Phase Modulation]** sequentially to enable PM.

- (2) **Set modulation signal parameters**

Following step (1), press the **[Modulation Frequency]** soft key, enter 200 using the numeric keypad, then select the unit Hz.

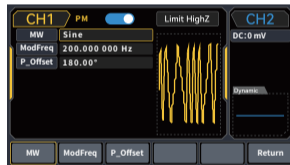

(3) Set carrier signal waveform and parameters

Press the Wave key to enter the carrier waveform selection screen, then select Square wave as the carrier (default is Sine wave).

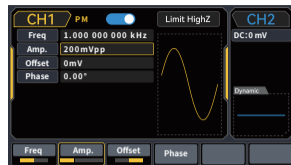

Tap the **[Frequency]** soft key to set the frequency, enter 900 using the numeric keypad, then select the unit Hz.

Tap the **[Amplitude]** soft key to set the amplitude, enter 100 using the numeric keypad, then select the unit mVpp.

As shown in the image on the right.

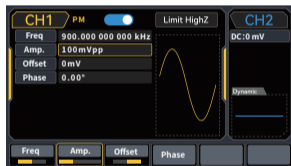

(4) Set phase offset

After setting the carrier parameters, press **[Mode]** → **[Phase Modulation]** to enter the PM settings.

Press the **[Phase Offset]** soft key, enter 200 using the numeric keypad, then select the unit °.

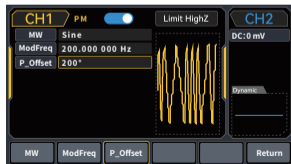

(5) Enable channel output

Press the CH1 key. The indicator light on means the channel output is enabled.

► 4.1.3 Frequency Modulation (FM)

In frequency modulation, the modulated waveform usually consists of a carrier and a modulation wave, where the carrier's frequency varies with the amplitude of the modulation wave.

• Select FM modulation:

Press **[Mode]** → **[Frequency Modulation]** sequentially. After enabling FM, the instrument outputs the modulated waveform based on the current modulation and carrier settings.

• Select carrier waveform:

The carrier waveform can be sine, square, ramp, or arbitrary wave, with sine wave as the default. After selecting FM modulation, press the **[Wave]** key to enter the carrier waveform selection screen.

• Set carrier frequency:

Refer to the AM carrier frequency settings.

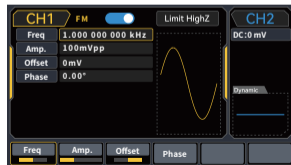
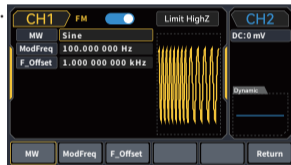

• Select modulation wave:

If the modulation source is internal, the modulation wave can be sine, square, rising ramp, falling ramp, arbitrary wave, or noise. The default is sine wave. After enabling the FM function, the modulation wave defaults to sine. To change it, use the multifunction knob or press “Modulation Wave” in the FM settings screen.

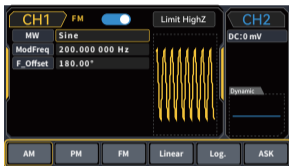

- » Square wave: Duty cycle 50%
- » Rising ramp: Symmetry 100%
- » Falling ramp: Symmetry 0%
- » Arbitrary wave: When selected as the modulation waveform, the function/arbitrary waveform generator limits the wave to 4kpts using automatic sampling
- » Noise: White Gaussian noise

• Set modulation frequency:

Set the modulation wave frequency, ranging from 2mHz to 200kHz (default is 100Hz). After enabling FM, the modulation frequency defaults to 100Hz. To change it, use the multifunction knob in the FM settings screen, or press the “Modulation Frequency” soft key, enter a value using the numeric keypad, then select the desired unit.

- **Set frequency deviation:**

Frequency deviation refers to how much the FM-modulated waveform's frequency deviates from the carrier frequency. The adjustable range is from minimum DC to half of the current carrier bandwidth. The default is 1kHz.

To change it, after enabling FM, press the **【Frequency Deviation】** soft key.

» Frequency deviation \leq carrier frequency. If the deviation value exceeds the carrier frequency, the instrument automatically limits it to the maximum allowed by the current carrier frequency.

» The sum of frequency deviation and carrier frequency \leq the maximum frequency allowed for the current carrier. If the deviation is set to an invalid value, the instrument automatically limits it to the maximum allowed by the carrier frequency.

- **Example:**

Set the instrument to Frequency Modulation (FM) mode. Then set a 2 kHz square wave from the internal source as the modulation signal, and a 10 kHz sine wave with 100 mVpp amplitude as the carrier signal. Finally, set the frequency deviation to 5 kHz. The detailed steps are as follows:

(1) Enable Frequency Modulation (FM)

Press **[Mode]** → **[Frequency Modulation]** sequentially to enable FM.



(2) Set modulation signal parameters and waveform

Following step 1), press the **[Modulation Wave]** soft key and select Square wave as the modulation waveform. Then press the **[Modulation Frequency]** soft key, enter 2 using the numeric keypad, and select the unit kHz.



(3) Set carrier signal waveform and parameters

Press the **[Wave]** key to enter the carrier waveform selection interface, then select sine wave as the carrier (default: sine wave).

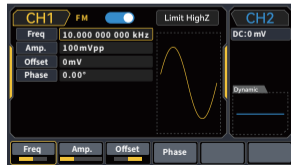

Press the **[Frequency]** soft key to set the frequency. Use the numeric keypad to enter 10, then select the unit kHz.

Press the **[Amplitude]** soft key to set the amplitude. Use the numeric keypad to enter 100, then select the unit mV.

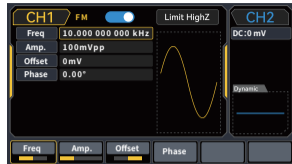

(4) Set frequency offset

After completing the carrier parameter settings, press **[Mode]** → FM soft key to enter FM settings.

Press the **[Freq Offset]** soft key, use the numeric keypad to enter 5, then select the unit kHz.



(5) Enable channel output

Press the CH1 key. When the indicator light is on, the channel output is enabled.

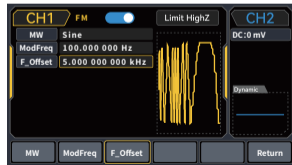

►4.1.4 Frequency-shift keying (FSK)

In frequency-shift keying mode, the instrument can be configured to switch between the carrier frequency and the shift frequency at a set rate.

•Select FSK modulation:

Press **[Mode]** → **[FSK]** sequentially to enable FSK. The instrument will output the modulated waveform based on the current settings.

•Select carrier waveform:

The carrier waveform can be sine, square, ramp, or arbitrary wave, with sine wave as the default. After selecting FM modulation, press the **[Wave]** key to enter the carrier waveform selection interface.

•Set carrier frequency:

Please refer to the AM carrier frequency.

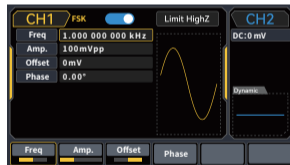
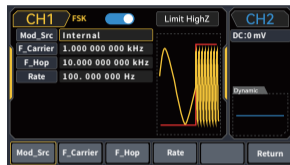

•Select modulation source:

This product allows selecting modulation source from internal or external. After enabling the FSK function, the modulation source defaults to internal. To change it, use the multifunction knob or press **[Mod Source]** → **[External]** soft key sequentially in the FSK settings interface to switch the modulation source to external.

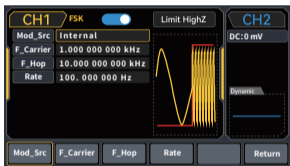

»Internal source: When the modulation source is set to internal, the internal modulation waveform is a 50% duty cycle square wave (fixed). The FSK rate setting determines the switching frequency between the carrier frequency and the shift frequency.

»External source: When the modulation source is set to external, the carrier waveform is modulated by the external waveform. The FSK output frequency is controlled by the logic level at the external digital modulation input (INPUT/CNT port). For example, when the external input is logic low, the carrier frequency is output; when the external input is logic high, the shift frequency is output.

•Set shift frequency:

After enabling the FSK function, the shift frequency defaults to 10 kHz. To change it, use the multifunction

knob combined with the arrow keys or press the “Shift Frequency” soft key, then enter the value via the numeric keypad and confirm by pressing the corresponding unit soft key. The adjustable range of the shift frequency depends on the carrier waveform. For carrier frequency settings of each waveform, please refer to the AM carrier frequency section.

- Set FSK rate:

When the modulation source is set to internal, the switching frequency between the carrier frequency and the shift frequency (FSK rate) can be configured. After enabling the FSK function, the FSK rate can be set within the range of 2 mHz to 100 kHz. The system default is 100 Hz. To change it, use the multifunction knob combined with the arrow keys or press the “Rate” soft key, then enter the value via the numeric keypad and confirm by pressing the corresponding unit soft key.

- Comprehensive example:

First, set the instrument to operate in frequency-shift keying (FSK) mode. Then configure an internal sine wave with 2 kHz frequency and 1 Vpp amplitude as the carrier signal, and set the shift frequency to 800 Hz. Let the carrier frequency and shift frequency switch at a rate of 200 Hz. The detailed steps are as follows:

(1) Enable FSK function

Press **[Mode]** → **[FSK]** sequentially to enable FSK.

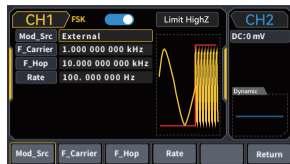

(2) Set shift frequency and modulation rate

Following step (1), press the **[Shift Frequency]** soft key, enter 800 using the numeric keypad, then select the unit Hz.

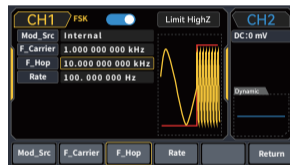

(3) Set modulation rate

Press the **[Rate]** soft key, enter 200 using the numeric keypad, then select the unit Hz.

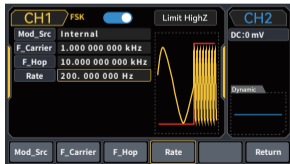

(4) Set carrier signal

Press the **[Wave]** key to enter the carrier waveform selection interface, then select sine wave as the carrier (default: sine wave).

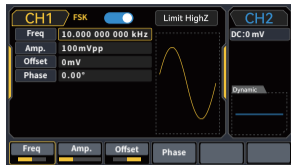

Press the **[Frequency]** soft key to set the frequency. Use the numeric keypad to enter 2, then select the unit kHz.

Press the **[Amplitude]** soft key to set the amplitude. Use the numeric keypad to enter 1, then select the unit Vpp.

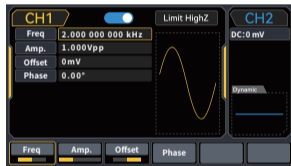

(5) Enable channel output

Press the CH1 key. The indicator light turning on means the channel output is enabled.

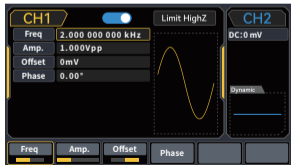

► 4.1.5 Amplitude-Shift Keying (ASK)

In amplitude-shift keying (ASK) mode, you need to set the keying frequency and the carrier frequency. The keying frequency determines how often the amplitude of the modulated waveform toggles.

- **Select ASK modulation:**

Press **[Mode]** → **[ASK]** sequentially to enable ASK.

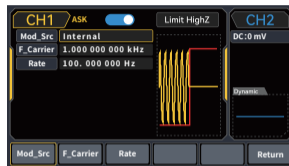

- **Select modulation source:**

Select the desired modulation source (Internal or External) as needed.

- **Internal modulation:**

In ASK internal modulation mode, the modulation waveform is a square wave with a 50% duty cycle.

- **External modulation:**

In ASK external modulation mode, the signal generator receives an external modulation signal through the **[Aux In/Out]** connector on the front panel. The external signal must be a square wave compliant with TTL level standards.

- **Rate:**

Defines the frequency at which the output amplitude switches between the carrier amplitude and 0. This can be set using the numeric keypad or the touch soft keyboard. The available range is 1 mHz to 1 MHz, with a default of 100 Hz.

- **Comprehensive example:**

Refer to the FSK example section.

► 4.1.6 Phase-Shift Keying (PSK)

In PSK mode, the rate determines the frequency at which the phase of the modulated waveform toggles. The modulation phase is set to 180° by default.

- **Select PSK modulation:**

Press **[Mode]** → **[PSK]** sequentially to enable PSK.

- **Select modulation source:**

Supports modulation waveforms from both internal and external sources. Press **[Mod Source]** to select “Internal” or “External”. The default is “Internal”.

- **Internal modulation:**

In PSK internal modulation mode, the modulation waveform is a square wave with a 50% duty cycle.

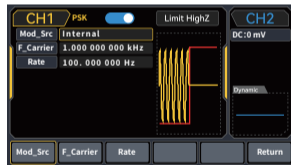

- **External modulation:**

In PSK external modulation mode, the signal generator receives an external modulation signal through the **[Aux In/Out]** connector on the front panel. The external modulation signal must be a square wave compliant with TTL level standards.

- **Rate:**

Specifies the frequency at which the output phase toggles. Set the rate using the numeric keypad or the on-screen soft keyboard. The range is from 1 mHz to 1 MHz, with a default value of 100 Hz. This parameter is not available when using external modulation.

- **Comprehensive example:**

Refer to the FSK example section.

4.2 Sweep Output Waveform

In sweep mode, the instrument outputs a waveform that changes frequency over a defined sweep time, either linearly or logarithmically. Sweep output is supported for sine, square, ramp, and arbitrary waveforms (except DC).

► 4.2.1 Select Sweep Mode

(1) Enable sweep function

Press **[Mode]** → **[Linear]** sequentially to enable the sweep function.

The instrument will output the sweep waveform based on the current settings.

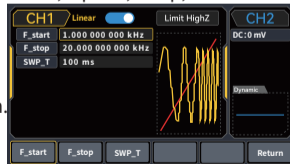

(2) Select sweep waveform

Sweep waveform options include sine wave, pulse wave, ramp wave, or arbitrary wave, with sine wave as the default. After selecting sweep mode, press the **[Wave]** key to enter the carrier waveform selection interface.

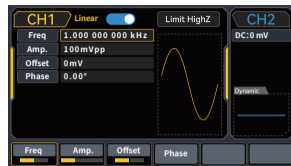

►4.2.2 Set Start and Stop Frequencies

The start frequency and stop frequency define the lower and upper limits of the frequency sweep. The function/arbitrary waveform generator always sweeps from the start frequency to the stop frequency, then returns to the start frequency. Press **[Mode]** → **[Linear]** sequentially to enter the sweep settings page. Use the multifunction knob and arrow keys together, or press the **[Start Frequency]** or **[Stop Frequency]** soft keys, then input the value using the numeric keypad and select the corresponding unit soft key to complete the setting.

- When the start frequency < stop frequency, the DDS function generator sweeps from low to high frequency.
- When the start frequency > stop frequency, the DDS function generator sweeps from high to low frequency.
- When the start frequency = stop frequency, the DDS function generator outputs a fixed frequency.

The default start frequency is 1 kHz, and the default stop frequency is 20 kHz. The allowable range of start and stop frequencies varies depending on the sweep waveform. Please refer to the table below for frequency setting ranges of different sweep waveforms:

Carrier Waveform	Frequency			
	TSG3020		TSG6020	
	Min	Max	Min	Max
Sine	1 μ Hz	30MHz	1 μ Hz	60MHz
Square	1 μ Hz	24MHz	1 μ Hz	24MHz
Ramp	1 μ Hz	20MHz	1 μ Hz	20MHz
Pulse	1 μ Hz	24MHz	1 μ Hz	24MHz
Arbitrary	1 μ Hz	10MHz	1 μ Hz	10MHz

Press the **[Amplitude]** soft key to set the amplitude. Use the numeric keypad to enter 1, then select the unit Vpp. Press the **[Duty]** soft key to set the duty cycle. Use the numeric keypad to enter 50, then select the unit % (default duty cycle is 50%).

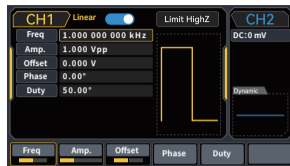

Set Start/Stop Frequency and Sweep Time:

Press the **[Mode]** soft key to enter Linear Sweep mode:

Press the **[Start Frequency]** or **[Stop Frequency]** soft key, enter 1 using the numeric keypad, then select the unit kHz. The default start frequency is 1 kHz.

Press the **[Stop Frequency]** soft key, enter 50 using the numeric keypad, then select the unit kHz.

Press the **[Sweep Time]** soft key, enter 2 using the numeric keypad, then select the unit ms.

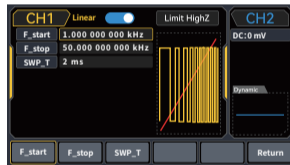

► 4.2.3 Sweep Mode

Press the **[Mode]** key to select between Linear and Logarithmic sweep:

- Linear: The waveform generator changes the output frequency linearly during the sweep.
- Logarithmic: The waveform generator changes the output frequency logarithmically during the sweep.

►4.2.4 Sweep Time

After enabling the sweep function, the sweep time (range: 1 ms~500 s) defaults to 100 ms. To change it, press the “Sweep Time” soft key on the sweep settings page, then enter the value using the numeric keypad and select the unit soft key.

►4.2.5 Comprehensive Example

In sweep mode, set a pulse wave with an amplitude of 1 Vpp and a duty cycle of 50% as the sweep waveform. Set the sweep mode to Linear, the start frequency to 1 kHz, the stop frequency to 50 kHz, and the sweep time to 2 ms. Use the internal source to trigger the sweep output. The detailed steps are as follows:

(1) Enable Linear Sweep

Press **[Mode]** → **[Linear]** sequentially to enable linear sweep.

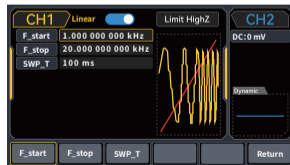

(2) Select Sweep Waveform

Press the **[Wave]** key to enter the sweep waveform selection interface, then select Square wave (default is Sine wave).

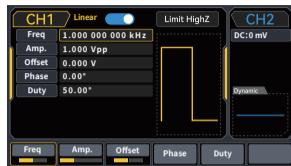

(3) Enable Channel Output

Press the CH1 key; the indicator light turns on to show the channel output is enabled.

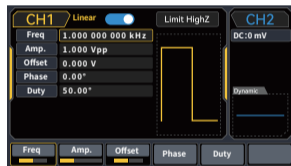

4.3 Output Arbitrary Waveforms

This product stores 24 types of arbitrary waveforms. Users can select the desired arbitrary waveform via the “Waveform File” option.

► 4.3.1 Enable Arbitrary Wave Function

Press **【Wave】** → **【Arbitrary Wave】** soft keys sequentially to enable the arbitrary wave function. The instrument outputs the arbitrary wave with the current settings.

► 4.3.2 Select Arbitrary Wave

Users can choose from the built-in arbitrary waveforms. After enabling the arbitrary wave function, use the multifunction knob and arrow keys or press the **【Waveform File】** soft key to select the desired arbitrary wave.

Built-in Arbitrary Wave List:

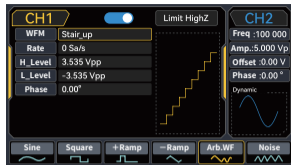

0	AmpALT	12	Log_up
1	AttALT	13	LogNormal
2	Cardiac	14	Lorentz
3	cosh	15	Pulseilogram
4	Dirichlet	16	Radar
5	EEG	17	sinc
6	EMG	18	SineVer
7	EOG	19	Stair down
8	Gauspuls	20	Stair up
9	Gmonopuls	21	Trapezia
10	Laplace	22	TV
11	Log_down	23	Voice

► 4.3.3 Mode Selection

Press **[DDS]** or **[Point-by-Point]** to switch between DDS mode and point-by-point mode.

- DDS Mode

In DDS output mode, parameter settings follow the same method as for sine wave signals. The device outputs the selected arbitrary waveform using DDS based on the current settings.

- Point-by-Point Mode

In point-by-point output mode, users can set the sampling rate (points per second) or frequency. Other parameters follow the same setting method as sine wave signals. The device outputs the selected arbitrary waveform in a point-by-point manner using the current settings.

5.TROUBLESHOOTING

Below are possible issues that may occur during the use of the instrument and their corresponding troubleshooting methods. Please follow the steps accordingly. If the issue persists, contact your distributor or local service office. Be sure to provide the device information (To retrieve: press Utility → System → About).

5.1 No Display (Black Screen)

If the signal generator remains unresponsive (black screen) after pressing the side panel power switch:

- ① Check if the power cable is properly connected.
- ② Check if the rear panel power switch is turned on and set to “I”.
- ③ Check if the front panel power switch is functioning properly.
- ④ Restart the instrument.
- ⑤ If the problem persists, please contact your distributor or local service office for support.

5.2 No Waveform Output

If the settings are correct but no waveform is being output:

- ① Check if the BNC cable is properly connected to the output channel.
- ② Check if the CH1 or CH2 button is turned on.
- ③ If the problem persists, please contact your distributor or local service office for assistance.

6. MAINTENANCE AND CARE

General Maintenance

- Do not store or place the instrument in areas where the LCD display may be exposed to direct sunlight for extended periods.
- To prevent damage to the instrument or cables, avoid placing it in misty environments or in contact with liquids or solvents.

Cleaning and Care

- Clean the instrument regularly based on usage conditions.
 - Disconnect the power before cleaning. Use a soft, damp (but not dripping) cloth. Mild detergents or clean water may be used to wipe off surface dust. Do not use harsh chemicals containing benzene, toluene, xylene, or acetone.
 - When cleaning instruments with an LCD display, be careful not to scratch the LCD protective screen.
 - Avoid any corrosive liquid contact with the instrument to prevent damage.
- !** **Warning:** Before reconnecting to power, ensure the instrument is completely dry. Moisture may cause electrical short circuits or pose a risk of personal injury.

7. CONTACT US

Product Name: Function Signal Generator

Brand / Model: TSG3020/TSG6020

Manufacturer: Shenzhen FNIRSI Technology Co., Ltd.

Address: 8th Floor, West Side of Building C, Weihuada Industrial Park, Dalang Street, Longhua District, Shenzhen, Guangdong, China

Service Hotline: +86-755-28020752

Service Email: support@fnirsi.com

Business Email: business@fnirsi.com

Official Website: <https://www.fnirsi.com/>

Compliance Standard: GB/T 9317-2012



<http://www.fnirsi.com/>

8.WARRANTY INFORMATION

※ **This page serves as the basic warranty certificate. Please keep it properly.**

Thank you for choosing our company's products. The warranty period of this product starts from the date of sale. During the product warranty period, if the product is installed and used in accordance with the product manual and used in normal environment and conditions, and the fault is caused by defects in the original materials and processing, you can enjoy free repair services according to the content of this warranty clause. Please keep this warranty card properly as a warranty certificate. No reissue will be issued if it is lost.

The following situations will incur paid repair services:

- Unable to present the original valid warranty card.
- Damage caused by improper installation not meeting product requirements, standards, or relevant specifications.
- Damage caused by accessories in the installation environment not meeting product requirements, standards, or relevant specifications.
- Damage caused by improper use, improper storage, unauthorized disassembly, or unauthorized repairs by the user.
- Expiration of the warranty period.

APPENDIX A: FACTORY RESET STATUS

Carrier Waveform	
Current Carrier	Sine Wave
Output Load	HighZ
Sync Output	Off
Channel Output	Off
Channel Output Invert	Off
Amplitude Limit	Off
Amplitude Upper Limit	+10V
Amplitude Lower Limit	-10V
Fundamental Wave	
Frequency	1kHz

Amplitude	100mVpp
DC Offset	0mV
Start Phase	0°
Square Wave Duty Cycle	50%
Ramp Wave Symmetry	100%
Pulse Duty Cycle	50%
Pulse Rise Time	12ns
Pulse Fall Time	12ns
Arbitrary Wave	
Built-in Arbitrary Wave	AbsSine
AM Modulation	
Modulation Source	Internal

Modulation Wave	Sine Wave
Modulation Frequency	100Hz
Modulation Depth	100%
FM Modulation	
Modulation Source	Internal
Modulation Wave	Sine Wave
Modulation Frequency	100Hz
Frequency Deviation	1kHz
PM Modulation	
Modulation Source	Internal
Modulation Wave	Sine Wave
Phase Modulation Frequency	100Hz

Phase Offset	180°
FSK Modulation	
Modulation Source	Internal
FSK Rate	100Hz
Shift Frequency	2MHz
Sweep	
Sweep Type	Linear
Start Frequency	1kHz
Stop Frequency	20kHz
Sweep Time	100ms
System Parameters	
Buzzer Volume	Max

Digit Separator	,
Backlight	100%
Language	Depends on Factory Settings

APPENDIX B: PERFORMANCE SPECIFICATIONS

Unless otherwise specified, all technical specifications are guaranteed under the following two conditions:

- ① The signal generator is within the calibration period and has been calibrated.
- ② The signal generator has been operating continuously for more than 30 minutes within the specified operating temperature (18°C to 28°C).

All specifications are guaranteed except those marked as "typical values."

Model	TSG3020	TSG6020
Channels	2 Channels	2 Channels
Max Frequency	30MHz	60MHz

Sampling Rate	200MSa/s	
Waveforms	Sine wave, Square wave, Triangle wave, Pulse wave, Noise, DC, Arbitrary waveforms	
Operating Modes	Output gating, Continuous, Modulation, Frequency sweep	
Modulation Types	AM, FM, PM, FSK, ASK, PSK, Line, Log	
Waveform Characteristics		
Sine Wave		
Frequency Range	1 μ Hz~30MHz	1 μ Hz~60MHz
Resolution	1 μ Hz	
Accuracy	\pm 50 ppm within 90 days, \pm 100 ppm within 1 year (18°C to 28°C)	
Harmonic Distortion (Typical)	DC~5MHz	- 60dBc

Harmonic Distortion (Typical)	5MHz~30MHz:	- 50dBc
	30MHz~60MHz:	- 40dBc
Total Harmonic Distortion (Typical)	<0.2% (DC~20kHz, 1Vpp)	
Spurious Signals (Non-harmonic, Typical)	DC~10MHz, < - 70dBc	
	> 10MHz < - 70dBc + 6dB / Octave	
Phase Noise (Typical)	10 MHz: \leq - 125 dBc/Hz (Typical, 0dBm, 10kHz Offset)	
Square Wave		
Frequency Range	1 μ Hz~24MHz	1 μ Hz~24MHz
Resolution	1 μ Hz	
Rise / Fall Time	13.5ns (Typical, 1kHz, 1Vpp)	
Overshoot (Typical)	\leq 1%	
Duty Cycle	0.01%~99.99%(limited by current frequency setting)	

Symmetry (at 50% duty cycle)	1ns + 100ppm of the period	
Jitter (typical value)	Typical value (1MHz, 1Vpp, 50Ω)	
	≤5MHz: 2ppm + 200ps	
	>5MHz: 200ps	
Ramp wave		
Frequency range	1μHz – 20MHz	1μHz – 20MHz
Resolution	1μHz	
Nonlinearity	3%±2 mV (typical value, 1kHz, 1Vpp, 50% symmetry)	
Symmetry	0.0% to 100.0% (limited by current frequency setting)	
Pulse wave		
Frequency range	1μHz - 24MHz	1μHz - 24MHz
Resolution	1μHz	

Pulse width	$\geq 17\text{ns}$	
Variable edge	$\geq 12\text{ns}$	$\geq 12\text{ns}$
Overshoot (typical value)	$\leq 2\%$ (typical, 1Vpp)	
Jitter	150ps	
Gaussian noise		
Bandwidth	30MHz bandwidth (-3dB) (typical)	60MHz bandwidth (-3dB) (typical)
DC offset	9.999V	
Range (peak AC + DC)	$\pm 5\text{V}$ (50 Ω)	$\pm 10\text{V}$ (High Z)
Offset accuracy	$\pm 3\%$ of bias setting value $\pm 6\%$ of amplitude setting value $\pm 2\text{mV}$	
Arbitrary waveform characteristics		
Frequency range	1 μHz - 10MHz	1 μHz - 10MHz
Resolution	1 μHz	

Waveform Length	4kpts	
Vertical Resolution	14bits (Including Sign)	
Sampling Rate	200MSa/s	
Minimum Rise / Fall Time	< 20ns Typical Value	< 20ns Typical Value
Jitter	DDS Mode:5ns±150ps; Point-by-Point Mode:±150ps	
Non-Volatile Memory	24 Waveforms	
Output Characteristics		
Amplitude Range	≤10MHz:1mVpp - 10Vpp; (50Ω)	≤60MHz:1mVpp - 5Vpp; (50Ω)
Accuracy (1kHz Sine Wave)	±(5% of the set value + 2mVpp)	
Amplitude Flatness (Relative to 1kHz Sine Wave, 1Vpp/50Ω)	Test Conditions: Typical Value (Sine Wave, 2.0Vpp) ≤100kHz : ±0.1dB ≤20MHz : ±0.3dB ≤30MHz : ±0.5dB ≤40MHz : ±0.6dB ≤60MHz : ±0.8dB	

Waveform Output	
Impedance	50Ω (typical)
Insulation	Max 42Vpk to ground
Protection	Channel Protection

Modulation Type			
AM Modulation		FM Modulation	
Carrier	Sine, Square, Triangle, Arbitrary Wave	Carrier	Sine, Square, Triangle, Arbitrary Wave
Modulation Wave	Sine, Square, Triangle, Noise, Arbitrary Wave	Modulation Wave	Sine, Square, Triangle, Noise, Arbitrary Wave
Modulation Frequency	2mHz - 200kHz	Modulation Frequency	1μHz - 200kHz
Modulation Depth	0% - 120%	Frequency Deviation	DC - 15MHz (UTG932) DC - 30MHz (UTG962)

Modulation Type			
PM Modulation		FSK Modulation	
Carrier	Sine, Square, Triangle, Arbitrary Wave	Carrier	Sine, Square, Triangle, Arbitrary Wave
Modulating Wave	Sine, Square, Triangle, Noise, Arbitrary Wave	Source	Internal / External
Modulation Frequency	2mHz - 200kHz	Modulating Wave	50% Duty Cycle Square Wave
Phase Offset	0° - 360°	Rate	2mHz - 100kHz

Frequency Sweep	
Carrier	Sine, Square, Triangle, Arbitrary Wave
Type	Linear, Logarithmic
Sweep Time	1ms - 500s ± 0.1%
Sync Signal	

Output Level	TTL Compatible
Output Frequency	1 μ Hz - 2MHz
Output Impedance	50 Ω , Typical
Coupling Mode	DC
Trigger Input	
Input Level	TTL Compatible
Input Impedance	>10k Ω , DC Coupled
Frequency Counter	
Input Level	TTL Compatible
Input Frequency Range	100mHz - 100MHz
Accuracy	\pm 51ppm
Frequency Resolution	7 bits

Coupling Mode	DC
General Specifications	
Display	
Display Type	4.3-inch TFT LCD
Display Resolution	480 Horizontal × 272 Vertical
Power Supply Voltage	DC5V, 2A
Power Consumption	<10W
Environment	
Temperature Range	Operating Temperature: 10°C - +40°C
	Non-operating Temperature Range: -20°C - +60°C
Cooling Method	Natural Cooling
Humidity Range	Below +35°C: ≤90% Relative Humidity

Humidity Range	+35°C to +40°C: ≤60% Relative Humidity
Altitude Operating	Altitude Operating: Below 2000 meters
	Non-operating: Below 15000 meters
Mechanical Specifications	
Dimensions (Reference)	172mm×90mm×68mm
Net Weight	≈732.6g
Gross Weight	≈1191g

APPENDIX C: ACCESSORIES LIST

Model	TSG6000
Standard accessories	One power adapter meeting local standards
	One BNC to alligator clip cable
	One BNC cable (1 meter)
	One product warranty card

Power adapter

Input voltage	100 - 240Vrms , 50/60Hz , 0.4A
Output voltage	5VDC
Output current	2A



保修卡



产品型号	TSG3020/TSG6020	数量	
渠道商名称 (购买商店)		联系方式	
渠道商地址		发票号 (订单号)	
购买时间	年 月 日		
客户姓名:	地址: 		
联系方式: 	故障说明: 		

Warranty Card



Product Model	TSG3020/TSG6020	Qty.	
Distributor Name (where to buy)		Contact	
Address		Invoice Number (Order Number)	
Purchase Date (as per invoice)	Year	Month	Day
User Name:	Address:		
			
Contact:	Fault Description:		
			



下载用户手册&应用软件
Download User manual&APP&Software